

Developer Note

LaserWriter 16 / 600 PS Printer

030-6625-A

September 1994

Developer Press

© Apple Computer, Inc. 1994

Apple Computer, Inc.
© 1994 Apple Computer, Inc.
All rights reserved.

No part of this publication may be reproduced, stored in a retrieval system, or transmitted, in any form or by any means, mechanical, electronic, photocopying, recording, or otherwise, without prior written permission of Apple Computer, Inc. Printed in the United States of America.

The Apple logo is a trademark of Apple Computer, Inc. Use of the "keyboard" Apple logo (Option-Shift-K) for commercial purposes without the prior written consent of Apple may constitute trademark infringement and unfair competition in violation of federal and state laws.

No licenses, express or implied, are granted with respect to any of the technology described in this book. Apple retains all intellectual property rights associated with the technology described in this book. This book is intended to assist application developers to develop applications only for Apple Macintosh computers.

Every effort has been made to ensure that the information in this manual is accurate. Apple is not responsible for printing or clerical errors.

Apple Computer, Inc.
1 Infinite Loop
Cupertino, CA 95014
408-996-1010

Apple, the Apple logo, APDA, AppleLink, AppleTalk, EtherTalk, LaserWriter, LocalTalk, Macintosh, and TrueType are trademarks of Apple Computer, Inc., registered in the United States and other countries.

FinePrint, PhotoGrade, and Power Macintosh are trademarks of Apple Computer, Inc.

Adobe Illustrator, Adobe Photoshop, and PostScript are trademarks of Adobe Systems Incorporated, which may be registered in certain jurisdictions.

America Online is a registered service mark of America Online, Inc.

CompuServe is a registered service mark of CompuServe, Inc.

FrameMaker is a registered trademark of Frame Technology Corporation.

Helvetica, Palatino, and Times are registered trademarks of Linotype Company.

HP LaserJet is a registered trademark of Hewlett-Packard Corporation.

Internet is a trademark of Digital Equipment Corporation.

ITC Zapf Dingbats is a registered trademark of International Typeface Corporation.

UNIX is a registered trademark of UNIX Laboratories, Inc.

Simultaneously published in the United States and Canada.

LIMITED WARRANTY ON MEDIA AND REPLACEMENT

If you discover physical defects in the manual or in the media on which a software product is distributed, APDA will replace the media or manual at no charge to you provided you return the item to be replaced with proof of purchase to APDA.

ALL IMPLIED WARRANTIES ON THIS MANUAL, INCLUDING IMPLIED WARRANTIES OF MERCHANTABILITY AND FITNESS FOR A PARTICULAR PURPOSE, ARE LIMITED IN DURATION TO NINETY (90) DAYS FROM THE DATE OF THE ORIGINAL RETAIL PURCHASE OF THIS PRODUCT.

Even though Apple has reviewed this manual, APPLE MAKES NO WARRANTY OR REPRESENTATION, EITHER EXPRESS OR IMPLIED, WITH RESPECT TO THIS MANUAL, ITS QUALITY, ACCURACY, MERCHANTABILITY, OR FITNESS FOR A PARTICULAR PURPOSE. AS A RESULT, THIS MANUAL IS SOLD "AS IS," AND YOU, THE PURCHASER, ARE ASSUMING THE ENTIRE RISK AS TO ITS QUALITY AND ACCURACY.

IN NO EVENT WILL APPLE BE LIABLE FOR DIRECT, INDIRECT, SPECIAL, INCIDENTAL, OR CONSEQUENTIAL DAMAGES RESULTING FROM ANY DEFECT OR INACCURACY IN THIS MANUAL, even if advised of the possibility of such damages.

THE WARRANTY AND REMEDIES SET FORTH ABOVE ARE EXCLUSIVE AND IN LIEU OF ALL OTHERS, ORAL OR WRITTEN, EXPRESS OR IMPLIED. No Apple dealer, agent, or employee is authorized to make any modification, extension, or addition to this warranty.

Some states do not allow the exclusion or limitation of implied warranties or liability for incidental or consequential damages, so the above limitation or exclusion may not apply to you. This warranty gives you specific legal rights, and you may also have other rights which vary from state to state.

Contents

Figures and Tables v

Preface **About This Note** vii

What This Note Contains vii
Conventions and Abbreviations viii
 Typographical Conventions viii
 Standard Abbreviations viii
Other Reference Material ix
For More Information ix

Chapter 1 **Introduction to the LaserWriter 16/600 PS Printer** 1

Features of the Printer 3
Communication Ports 4
 Ethernet 5
 EtherTalk Protocols 5
 NetWare Protocols 5
 TCP/IP Protocols 6
 LocalTalk Connector 6
 Centronics Parallel Connector (IEEE 1284) 7
Configuration Switch 9
Memory Capabilities 11
 ROM Capability 11
 DRAM Expansion 11
Page Types 13
Paper Handling 14
Status Lights 15

Chapter 2 **LaserWriter 16/600 PS Software** 17

Software Overview 18
 Adobe PostScript Programming Language 18
 PostScript Interpreter 18
 Printer Driver 18
 Apple Printer Utility program 19
 Page and Envelope Types 19
Device Setup 21

Page Device Parameters	21
Page Device Parameters for /FaxReceived Devices	27
Page Device Parameters for /Fax devices	28
Fax Parameters	29
Details Dictionary	35
Product Strings	35
Interpreter Parameters	36
User Parameters	36
System Parameters	38
Device Parameters	44
Device Parameters for Type /FileSystem Devices	44
Communication Device Parameters	47
SCSI Bus Parameters	56
Engine Device Parameters	57
Fax Device Parameters	58
Emulator Parameters	61
Resource Categories	67
Regular Resource Categories	68
Key-Value Pairs for Fax Output Device Resources	70
Key-Value Pairs for FaxReceived Output Device Resources	70
Key-Value Pairs for Printer Output Device Resources	70
Implicit Resource Categories	71
Resource Categories for Defining New Resources	72
Resources for Accessing Hardware Options	73

Chapter 3	PostScript Level 1 Compatibility Operators	75
-----------	---	----

Overview of Compatibility Operators	76
Page Size Compatibility Operators	78
Paper Tray Compatibility Operators	79
Compatibility Operator Descriptions	79

Index	83
--------------	----

Figures and Tables

Chapter 1

Introduction to the LaserWriter 16/600 PS Printer 1

Figure 1-1	LaserWriter 16/600 PS side-panel connectors	5
Figure 1-2	Ethernet connector	5
Figure 1-3	The 9-pin mini-DIN connector for LocalTalk	6
Figure 1-4	The Centronics (IEEE 1284) parallel connector	7
Figure 1-5	Timing for Centronics interface	9
Figure 1-6	ROM, DRAM, and EPROM locations on the controller board	12
Figure 1-7	Paper handling options	14
Figure 1-8	LaserWriter 16/600 PS status lights	15
Table 1-1	LaserWriter 16/600 PS printer features	3
Table 1-2	Signal descriptions for LocalTalk connector	7
Table 1-3	Signal descriptions for the Centronics parallel port	8
Table 1-4	Configuration switch default parameter values	10
Table 1-5	DRAM configurations for the LaserWriter 16/600 PS printer	12
Table 1-6	Available page types	13
Table 1-7	Status light functions	15

Chapter 2

LaserWriter 16/600 PS Software 17

Table 2-1	Paper tray selection operators	20
Table 2-2	Page device parameters	22
Table 2-3	Paper sizes	26
Table 2-4	Paper tray slot numbers and input sources	27
Table 2-5	Page device parameters for a /FaxReceived device	27
Table 2-6	Page device parameters for a /Fax device	28
Table 2-7	Parameters for the FaxOptions dictionary	29
Table 2-8	Product string values	35
Table 2-9	User parameters in the LaserWriter 16/600 PS printer	37
Table 2-10	System parameters in the LaserWriter 16/600 PS printer	39
Table 2-11	Parameters for %disk0% devices	45
Table 2-12	Parameters for %rom% devices	46
Table 2-13	Parameters for %LocalTalk% and %LocalTalk_Pending%	48
Table 2-14	Parameters for %Parallel% and %Parallel_Pending%	50
Table 2-15	Parameters for %EtherTalk% and %EtherTalk_Pending%	52
Table 2-16	Parameters for %NetworkInterface% and %NetworkInterface_Pending%	53
Table 2-17	Parameters for network printers	55
Table 2-18	Parameters for %Scsi% bus devices	57
Table 2-19	Parameters for %Engine% devices	57
Table 2-20	Parameters for the %Fax% device	58
Table 2-21	Parameters for the %LaserJetIII% emulator	62

Table 2-22	Symbol Set code legal values	66
Table 2-23	Regular resource categories	68
Table 2-24	Resource dictionary for <code>Fax</code> output device instances	70
Table 2-25	Resource dictionary for <code>FaxReceived</code> output device instances	70
Table 2-26	Resource dictionary for <code>Printer</code> output device instances	70
Table 2-27	Resources with implicit instances	71
Table 2-28	Resources to define new categories	73
Table 2-29	Hardware option instances for the <code>HWOptions</code> resource category	73

Chapter 3

PostScript Level 1 Compatibility Operators 75

Table 3-1	Compatibility operators	77
Table 3-2	Page size compatibility operators	78
Table 3-3	Paper tray compatibility operators	79
Table 3-4	Tray numbers and descriptions for compatibility operators	80

About This Note

The LaserWriter 16/600 PS printer is a new member of the Apple Computer LaserWriter printer family. This developer note describes the features and capabilities of the printer and is intended for use by software and hardware developers.

To use this note, you must understand the Adobe™ PostScript™ Level 2 programming language and printer terminology referred to in PostScript programming documentation.

You do not need to use this note if you are simply running packaged programs for your Apple computer. Your owner's guide provides instructions for connecting the printer to your computer, inserting paper, and performing other routine operating tasks. This note does not provide that type of information.

This preface describes the contents of this note, explains visual cues and conventions, and lists other books to which you can refer.

What This Note Contains

This note consists of three chapters and an index.

- Chapter 1, "Introduction to the LaserWriter 16/600 PS Printer," describes the hardware features of the LaserWriter 16/600 PS printer, the built-in communication ports, and the printer's paper-handling capabilities.
- Chapter 2, "LaserWriter 16/600 PS Software," provides general information about the PostScript Level 2 programming language, the LaserWriter 16/600 PS driver, the utility program, and page types.
- Chapter 3, "PostScript Level 1 Compatibility Operators," describes the PostScript Level 1 compatibility operators present in the LaserWriter 16/600 PS printer. These operators enable the LaserWriter 16/600 PS printer, which uses PostScript Level 2, to maintain compatibility with software that uses PostScript Level 1 operators.

Conventions and Abbreviations

This developer note uses the following typographical conventions and abbreviations.

Typographical Conventions

Computer-language text—any text that is literally the same as it appears in computer input or output—appears in `Courier` font.

Certain terms used in this note may appear in different typographical formats—for example, `BuildTime` and `buildtime`. In this developer note, `BuildTime` is the format used for the system parameter, and `buildtime` is the format used for the `buildtime` operator.

Note

A note like this contains information that is interesting but not essential for an understanding of the text. ◆

IMPORTANT

A note like this contains important information that you should read before proceeding. ▲

▲ WARNING

A note like this directs your attention to something that could cause damage or result in a loss of data. ▲

Standard Abbreviations

When unusual abbreviations appear in this developer note, the corresponding terms are also spelled out. Standard units of measure and other widely used abbreviations are not spelled out. The following abbreviations are used in this note:

AIS	Adobe™ Intelligent Software
AMD	Advanced Micro Devices
dpi	dots per inch
DRAM	dynamic RAM
EEPROM	electrically erasable programmable ROM
EPROM	electrically programmable ROM
I/O	input/output
KB	kilobyte

continued

MB	megabyte
MHz	megahertz
PDL	page-description language
ppm	pages per minute
RAM	random-access memory
ROM	read-only memory
VM	virtual memory

Other Reference Material

This developer note assumes that you are familiar with printer technology and know how to operate and program Apple LaserWriter printers. Additional information is available in the following publications:

- The owner's guide that is shipped with every Apple printer explains how to set up the printer in the standard configuration. The guide gives basic operating information on how to load toner cartridges, load the paper tray, and set up an external hard disk for fonts. The owner's guide also provides basic troubleshooting information.
- *PostScript Language Reference Manual*, second edition, published by Addison-Wesley, is required if you plan to write programs in the PostScript Level 2 programming language. The supplement to this manual, the *PostScript Language Reference Manual Supplement for Version 2014*, is available from Adobe Systems, Inc.
- *PostScript Language Tutorial and Cookbook*, published by Addison-Wesley, provides a basic introduction to the PostScript programming language. It also includes sample PostScript programs that help you quickly understand how the PostScript programming language works.
- *PostScript Language Program Design*, published by Addison-Wesley, is written for programmers who want to take advantage of the PostScript programming language to design efficient PostScript programs and printer devices.

For More Information

APDA offers convenient worldwide access to hundreds of Apple and third-party development tools, resources, and information for anyone interested in developing applications on Apple platforms. For a free copy of the *APDA Tools Catalog*, call 1-800-282-2732 (United States), 1-800-637-0029 (Canada), or 716-871-6555 (International).

P R E F A C E

To order products or to request a complimentary copy of the *APDA Tools Catalog*, contact

APDA
Apple Computer, Inc.
P.O. Box 319
Buffalo, NY 14207-0319

Telephone 1-800-282-2732 (United States)
 1-800-637-0029 (Canada)
 716-871-6555 (International)

Fax 716-871-6511

AppleLink APDA

America Online APDAorder

CompuServe 76666,2405

Internet APDA@applelink.apple.com

Introduction to the LaserWriter 16/600 PS Printer

Introduction to the LaserWriter 16/600 PS Printer

The LaserWriter 16/600 PS printer is a mainstream network laser printer designed for midsize to large businesses, higher education institutions, Macintosh and non-Macintosh networks, and graphics and desktop publishing environments. Replacing the Apple LaserWriter Pro 630, it supports Adobe™ PostScript Level 2 programming functions and produces printed pages at a rate of up to seventeen letter-size pages per minute.

The LaserWriter 16/600 PS printer supports 600 dpi resolution. FinePrint can be selected to smooth text and line art. FinePrint technology gives the printer the ability to print dots of different widths, producing crisper text and graphics. Antialiasing smooths the jagged edges of both characters and lines, producing an effective resolution much greater than 600 dpi.

When configured with 12 MB or more of RAM memory, the LaserWriter 16/600 PS printer also supports 600 dpi PhotoGrade printing. Photograde technology allows the LaserWriter 16/600 PS printer to print photographs with as many as 97 shades of gray. Photographs printed using PhotoGrade technology retain a higher level of detail than other 600-dpi laser printers are capable of producing. PhotoGrade can designate more than one level of gray for each pixel by controlling the size of the dots.

In low-memory configurations (printers with less than 12 MB), the LaserWriter 16/600 PS printer employs a printing method referred to as super pixel dithering, which produces nearly as many levels of grey as PhotoGrade. However, images printed with PhotoGrade will display finer details and smoother shading.

The LaserWriter 16/600 PS printer is intended to work with several network interfaces simultaneously. The Ethernet port can be connected to any network that supports EtherTalk, TCP/IP, and Novell NetWare network protocols. The LocalTalk port may be connected to a network of one or more Macintosh computers, or any other computer that supports LocalTalk on a serial port. DOS-based IBM or IBM-compatible personal computers that are not on larger networks typically connect to the Centronics-style parallel port.

The LaserWriter 16/600 PS printer is Energy Star compliant and is available in 110-volt and 220-volt versions.

This chapter describes:

- hardware features
- communication ports
- interface configuration switch settings
- memory capabilities
- page types
- paper handling capabilities
- status lights

Features of the Printer

The LaserWriter 16/600 PS printer supports the entire PostScript Level 2 language as specified in the *PostScript Language Reference Manual*, second edition, as well as the PCL5 Printer Control Language. In addition, the LaserWriter 16/600 PS printer has features, capabilities, and operating modes not present in other PostScript language printers. You may access these additional facilities by executing special PostScript operators that exist only in the LaserWriter 16/600 PS printer's PostScript interpreter.

Because the LaserWriter 16/600 PS printer uses dynamic-interface switching and automatically selects the appropriate communication parameters and port based on the incoming data stream, the rotary switch on previous LaserWriters for selecting different communication protocol setups is not present. Communication parameters can be modified by using either the Apple Printer Utility on the Macintosh computer, the Windows LaserWriter Utility on Windows systems, or through PostScript operators. A two position configuration switch is located on the back of the printer. It is used for setting the interface ports to a set of known default parameters or for allowing software configuration. The default communication parameters are listed in Table 1-4 on page 10.

The printer has EEPROM (electrically erasable programmable ROM) that is used as nonvolatile storage. Any of the PostScript interpreter's default parameters that are changed using `statusdict` operators are placed in nonvolatile storage and will persist across power cycles. Table 1-1 lists functional features of the LaserWriter 16/600 PS printer.

Table 1-1 LaserWriter 16/600 PS printer features

Features	Specifications
Printing speed	16 pages per minute (ppm)
PostScript processing	50% faster than LaserWriter Pro 630
Imaging	User-selectable resolution and imaging features: <ul style="list-style-type: none"> ■ 600 dpi bilevel text and images ■ Selectable FinePrint text antialiasing ■ PhotoGrade
Processor	RISC processor (AMD 29030, 25 MHz)
I/O expansion options	Internal SCSI hard disk Fax card (USA, Canada) International fax card (UK, Germany, France)
Interface ports	Ethernet 14-pin Apple AUI connector (IEEE 802.3) 9-pin mini-DIN connector for LocalTalk Centronics (IEEE 1284) 36-pin bidirectional parallel port HDI-30 SCSI connector

continued

Table 1-1 LaserWriter 16/600 PS printer features (continued)

Features	Specifications
Paper handling	<p>Standard output: 250-sheet, 60-envelope, face-down tray</p> <p>Standard inputs: multipurpose tray for 100 sheets of paper or 7 envelopes, 250-sheet cassette feeder for U.S. letter or A4 size paper</p> <p>Optional inputs: 250-sheet universal cassette feeder, 500-sheet cassette feeder, 500-sheet universal cassette feeder, 75-sheet envelope feeder</p> <p>For more information, see the sections "Page Types," and "Paper Handling," at the end of this chapter</p>
ROM	4 MB of on-board masked ROM
DRAM	8 MB: 8 MB SIMM (single in-line memory module) Expandable to 32 MB using two 16 MB SIMMs
EEPROM	2 KB of on-board electrically erasable programmable memory
Fonts	35 PostScript Type I fonts
PDL (page description language)	Adobe PostScript Level 2, or compatible
Emulation	HP LaserJet III (PCL5), automatic emulation sensing and switching
Support for n-up printing	Allows 1, 2, or 4 pages to be printed on one sheet of paper

Communication Ports

The LaserWriter 16/600 PS printer includes I/O processing (IOP) hardware that supports three communication ports independently of the main controller processor. The communication ports on the LaserWriter 16/600 PS printer include:

- Ethernet 14-pin AUI connector
- 9-pin mini-DIN connector for LocalTalk
- Centronics 36-pin parallel port

Figure 1-1 shows the relative positions of the built-in ports on the side panel of the printer. The actual orientation of the connectors in the side panel is vertical, with the configuration switch at the top.

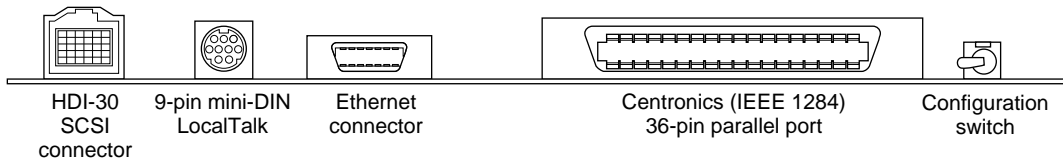
Figure 1-1 LaserWriter 16/600 PS side-panel connectors

Adobe Intelligent Software (AIS) detects the incoming data stream and selects between the ports during operation.

Ethernet

The LaserWriter 16/600 PS printer provides built-in support for Macintosh and PC-DOS Ethernet network protocols through a 14-pin AUI connector. Supported Ethernet protocols include EtherTalk, NetWare, and TCP/IP. The LaserWriter 16/600 PS printer uses dynamic protocol switching, which allows support for multiple Ethernet protocols running simultaneously on the same network medium.

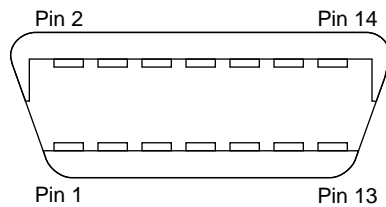
Figure 1-2 Ethernet connector

EtherTalk Protocols

The LaserWriter 16/600 PS printer supports PAP (printer access protocol), NBP (name binding protocol), ATP (AppleTalk transaction protocol), DDP (datagram delivery protocol), ZIP (zone information protocol), and AEP (echo protocol) EtherTalk protocols for both EtherTalk Phase I and EtherTalk Phase II Ethernet implementations.

NetWare Protocols

The LaserWriter 16/600 PS printer provides Ethernet support for complete SPX/IPX implementation of a Novell print server. NetWare versions 2.15, 2.20, 3.10, 3.11, and 4.0 are supported.

Introduction to the LaserWriter 16/600 PS Printer

The print server environment includes support for both remote printer mode and dedicated print server mode. The following server features are also supported:

- multiple file servers
- multiple file queues
- automatic reattachment to the file server
- encrypted passwords
- compatibility with Novell Print Server VAP/NLM/EXE

TCP/IP Protocols

In the TCP/IP environment the LaserWriter 16/600 PS printer appears as a remote UNIX[®] system with an attached printer. Users on the TCP/IP network perform print job setup and spool print jobs for the LaserWriter 16/600 PS printer to a spool directory through the `lpr` command. The UNIX system `lpd` (line printer daemon) scans the spool directory and when it encounters a print job it sends it to the specified printer.

The LaserWriter 16/600 PS printer TCP/IP network implementation includes support for

- Telnet configuration
- `lpd` (line printer daemon)
- multitasking kernel support for up to five hosts
- IP, TCP, UDP, ICMP, ARP, RARP, and BOOTP protocols

The UNIX system network administrator must configure the following network parameters for the LaserWriter 16/600 PS printer:

- IP address
- subnet mask and default network gateway
- printer type: PostScript, PCL, or ASCII
- banner pages always on or always off

LocalTalk Connector

An 9-pin mini-DIN connector supports the LocalTalk protocol. Figure 1-3 shows the connector pin designations for the 9-pin connector.

Figure 1-3 The 9-pin mini-DIN connector for LocalTalk

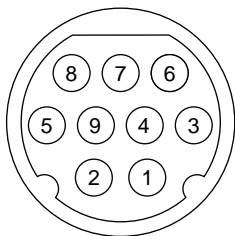

Table 1-2 lists the pin functions for the 9-pin mini-DIN connector for LocalTalk.

Table 1-2 Signal descriptions for LocalTalk connector

Pin number	Signal name	Description
1, 2, 7	NC	Not connected
3	/TXD	Transmit data (inverted)
4	GND	Signal ground
5	/RXD	Receive data (inverted)
6	TXD	Transmit data
8	RXD	Receive data
9	+5	+5 volts power

Note

In the LaserWriter 16/600 PS printer, the /TXD signal is connected to the /RXD signal, and the TXD signal is connected to the RXD signal. ♦

Centronics Parallel Connector (IEEE 1284)

The LaserWriter 16/600 PS printer provides a 36-pin connector for bidirectional communication with a Centronics (IEEE1284) parallel interface. The connector is fully compatible with the IBM PC Centronics port, and from a software perspective, the port operates exactly as a Hewlett-Packard LaserJet 4 Bi-Tronics parallel interface. The Centronics interface also supports the high-speed parallel interface. The high-speed capability of the parallel port can be enabled or disabled with the Macintosh Apple Printer Utility or the Windows LaserWriter Utility, as well as with PostScript operators.

The parallel channel is basically unidirectional and is used to input information from the host computer to the printer. The printer returns minimal status information to the host, such as PAPER ERR and /FAULT, which flag paper errors. It also returns handshaking signals such as BUSY and /ACK.

Figure 1-4 shows the pin designations for the parallel connector, and Table 1-3 lists the signal descriptions. Signal names in parenthesis are specific to the IEEE 1284 interface. Figure 1-5 shows the timing requirements for the Centronics interface.

Figure 1-4 The Centronics (IEEE 1284) parallel connector

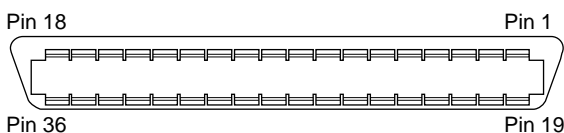

Note

In Table 1-3, inputs and outputs are referenced to the printer. This means that an input (I) is a signal sent from the host computer to the printer, and an output (O) is a signal sent by the printer to the host. ♦

Table 1-3 Signal descriptions for the Centronics parallel port

Pin number	Signal name	I/O	Description
1	/STROBE (HostClk)	I	Strobe for parallel input data
2	DATA 0	I	Data input bit 0
3	DATA 1	I	Data input bit 1
4	DATA 2	I	Data input bit 2
5	DATA 3	I	Data input bit 3
6	DATA 4	I	Data input bit 4
7	DATA 5	I	Data input bit 5
8	DATA 6	I	Data input bit 6
9	DATA 7	I	Data input bit 7
10	/ACK (PtrClk)	O	Handshaking output signal; printer uses this signal to acknowledge receipt of parallel data
11	BUSY (PtrBusy)	O	Busy output signal; indicates that a /STROBE signal has been received, but that /ACK has not yet been given
12	PAPER ERR (AckDataReq)	O	Paper error, an output error signal; indicates the printer has run out of paper
13	SELECT (Xflag)	O	Printer select line; driven high to indicate the LaserWriter 16/600 PS printer is online
14	/AUTOFEED (HostBusy)	I	
15, 34	Not connected	–	These lines are not connected
17	GND	–	Chassis ground
18, 33, 35	Tied high	–	Not used, tied high
16, 19-30	GND	–	Signal ground
31	INPRIME (nInit)	I	Reset signal; host CPU asserts this signal to cancel the current job on this port

continued

Table 1-3 Signal descriptions for the Centronics parallel port (continued)

Pin number	Signal name	I/O	Description
32	/FAULT (nDataAvail)	O	Fault signal; asserted if there is a printer problem
36	/SELECTIN (1284 Active)	I	

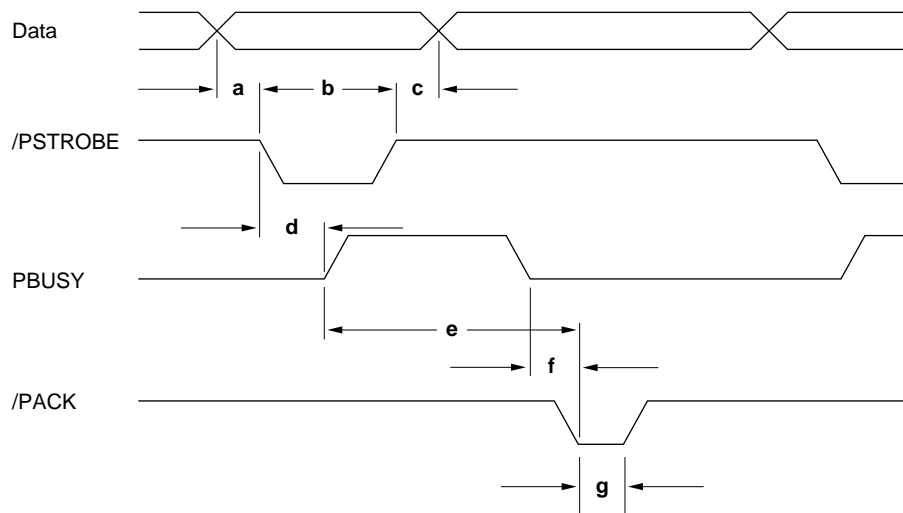
Figure 1-5 Timing for Centronics interface

Configuration Switch

The LaserWriter 16/600 PS printer has a two-position configuration switch for setting the parameters for the communication ports to a preset state or to a user-defined state. This configuration switch allows users to return the printer to a set of preset communication parameters when a user-defined parameter set is causing difficulty communicating with the printer.

When the switch is in the down position, the printer uses preset communication parameters that should work for the majority of LaserWriter 16/600 PS printer users. The preset communication parameters cannot be modified and persist when the switch is in the down position. Changes made to the communication parameter set using the Apple Printer Utility, LaserWriter Utility for Windows, or low-level PostScript operators are saved to nonvolatile RAM regardless of what position the switch is in, but the changes are not used for any print job until the switch is moved to the up position.

When the switch is in the up position (user-defined), any changes made to the communication parameters will affect the next print job. See Chapter 2, "LaserWriter 16/600 PS Software," for further information about the communication parameters. Table 1-4 shows the default parameter values for the configuration switch.

Table 1-4 Configuration switch default parameter values

Setting	Port name	Type of connection and default parameter values	Interpreter
Preset (Down, logical 0)	9-pin mini-DIN	LocalTalk	PostScript
	36-pin parallel (IEEE 1284)	Centronics (IEEE 1284), fast mode Protocol: Raw	AutoSelect
	Ethernet	EtherTalk NetWare TCP/IP	PostScript AutoSelect AutoSelect
User defined (Up, logical 1)	9-pin mini-DIN	LocalTalk	PostScript
	36-pin parallel	Centronics (IEEE 1284), fast mode Protocol: Normal	PostScript
	Ethernet	EtherTalk NetWare TCP/IP	PostScript PostScript PostScript

The configuration switch gives users connected to the parallel port of the LaserWriter 16/600 PS printer a way to recover from a situation where the LaserWriter Utility cannot communicate with the printer. For example, when the configuration switch is in the up position and the parallel port communication parameters are set to PCL5, the LaserWriter Utility cannot send commands to the printer because the utility uses PostScript commands rather than PCL5 commands to modify printer behavior. Moving the switch to the down position returns the parallel port to the AutoSelect mode. In this mode, the parallel port is automatically configured for the PostScript data stream from the LaserWriter Utility.

You can find out what the setting of the current switch position is by

- using the PostScript Level 2 system parameter `PrinterMode`
- choosing Configure Communication from the Utilities menu of the Apple Printer Utility program
- looking at the configuration switch on the back of the printer

Note

Changing the configuration switch to the user-defined position during a printing operation affects the next print job and does not modify parameters for the job in progress. Turning off the Ethernet channel will not take effect until the printer has been powered off and then powered back on again. ♦

Memory Capabilities

The LaserWriter 16/600 PS printer comes with 4 MB of masked ROM (MROM) and 8 MB of DRAM installed in the first DRAM SIMM socket on the main circuit board or controller. Figure 1-6 shows the positioning of the EPROM, DRAM, and ROM in relationship to the other components on the controller board.

ROM Capability

The LaserWriter 16/600 PS printer has 4 MB of MROM installed on the controller board to store the diagnostic software, fonts, and the PostScript and PCL interpreter required by the printer.

DRAM Expansion

The LaserWriter 16/600 PS printer comes with 8 MB of DRAM installed in the first bank of the two 72-pin DRAM SIMM slots on the main circuit board (see Figure 1-6). The SIMM slots accept 72-pin 80 nanosecond DRAM SIMMs, like those used in the LaserWriter Pro 630 printer and Power Macintosh computer. A total of 32 MB of DRAM can be installed in the LaserWriter 16/600 PS printer.

Figure 1-6 ROM, DRAM, and EPROM locations on the controller board

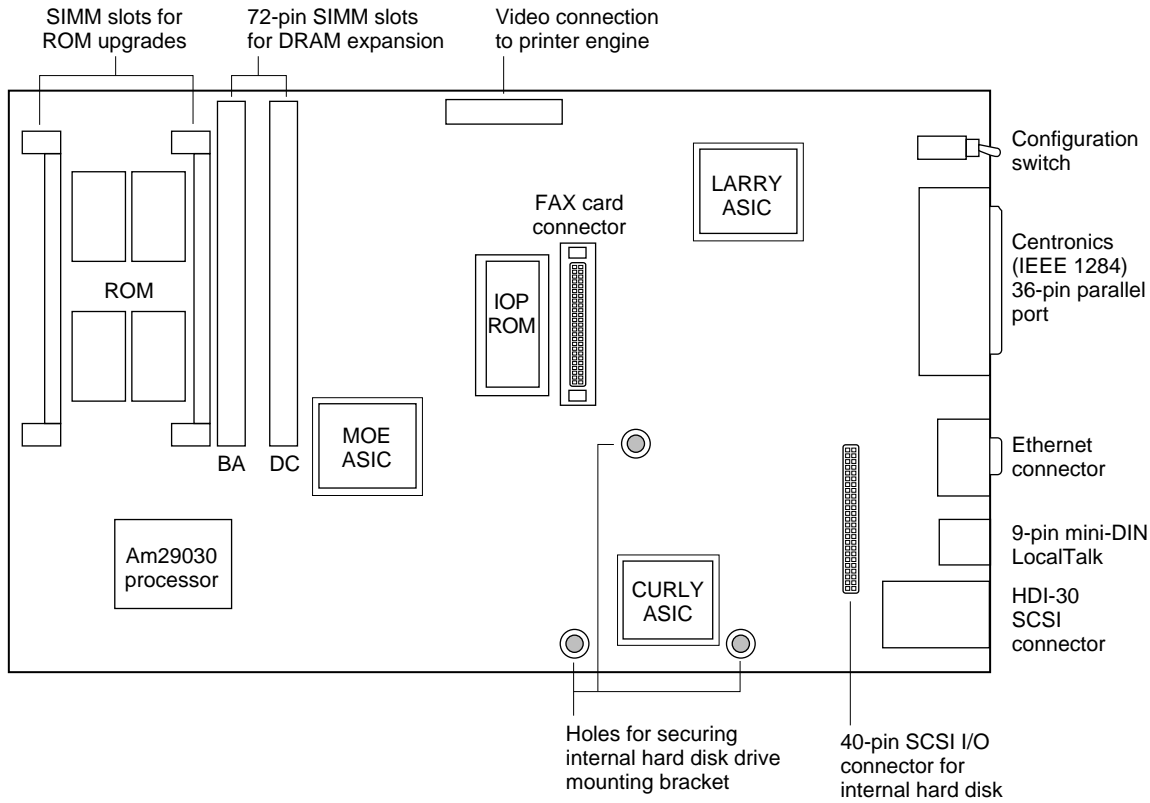

Table 1-5 lists the possible DRAM configurations for 4, 8, and 16 MB SIMMs installed in the LaserWriter 16/600 PS printer.

Table 1-5 DRAM configurations for the LaserWriter 16/600 PS printer

BA SIMM bank	DC SIMM bank	Total installed DRAM
8 MB	0 MB	8 MB
8 MB	4 MB	12 MB
8 MB	8 MB	16 MB
16 MB	8 MB	24 MB
16 MB	16 MB	32 MB

Note

The larger SIMM must always be installed in the B A SIMM bank. Otherwise, the printer will fail to come online and the Paper Jam and Paper Out lights will flash indicating a printer error. ♦

Page Types

The page size (the area in which printed output may appear) is constrained by

- the physical size of the paper (paper size)
- the margins required by the printing engine
- the amount of memory available for the full-page frame buffer

Table 1-6 lists the range of page sizes supported by the LaserWriter 16/600 PS printer.

Table 1-6 Available page types

Name	Paper size in inches	Page size in inches	Description
a4	8.26 x 11.69	7.84 x 11.42	Standard page type for European A4-size paper
a4small	8.26 x 11.69	7.47 x 10.85	Smaller version of A4
a5	5.83 x 8.26	5.83 x 11.69	Standard page type for A5-size paper
b5	7.17 x 10.11	6.97 x 9.72	Standard page type for Japanese B5-size paper
c5	6.38 x 9.01	5.98 x 8.62	Standard page type for the C5-size envelope
com10	4.13 x 9.5	3.73 x 9.1	Standard page type for the COM10-size envelope
dl	4.33 x 8.67	3.93 x 8.26	Standard page type for the DL-size envelope
legal	8.5 x 14	8.1 x 13.67	Standard page type for legal-size paper
legalsmall	8.5 x 14	8.1 x	Smaller version of legal size
letter	8.5 x 11	8.1 x 10.67	Standard page type for letter-size paper
lettersmall	8.5 x 11	7.68 x 10.16	Smaller version of letter size
monarch	3.88 x 7.5	3.47 x 7.1	Standard page type for the Monarch-size envelope

NOTE 1. The margins required in all cases are 0.2 inches on each side, and at the top and bottom.

NOTE 2. All images may be centered either horizontally or vertically, with the exception of b5, which must be centered horizontally.

NOTE 3. See the sections "Page Size Compatibility Operators," and "Paper Tray Compatibility Operators," in Chapter 3 for further information.

Paper Handling

The LaserWriter 16/600 PS printer offers a variety of paper handling features.

- The multipurpose tray is an integral part of the printer. To use it, you pull down a small flap on the front of the printer. You may use it to feed up to 100 sheets of paper of various sizes, as well as envelopes, transparency film, and sheets of labels. The tray can also be used for manual feed jobs.
- The 250-sheet cassette feeder pulls out like a drawer from the front of the printer. It holds 250 sheets of either U.S. letter-size or A4 paper.
- An optional 250-sheet universal cassette feeder holds four paper sizes: A4, B5, legal, and letter.
- An optional 500-sheet cassette feeder for either U.S. letter or A4 paper is a separate unit. It is installed under the LaserWriter 16/600 PS printer. It holds 500 sheets of
- An optional 500-sheet universal cassette feeder accommodates paper sizes A4, B5, legal, and letter.
- An optional envelope feeder can be installed, which holds up to 75 envelopes.

The standard configuration of the printer comes with

- the 100-sheet multipurpose tray
- the 250-sheet cassette feeder

As shown in Figure 1-7, if you use the basic printer with additional optional feeders, you can extend the printer's paper-feeding capability to 850 sheets.

Figure 1-7 Paper handling options

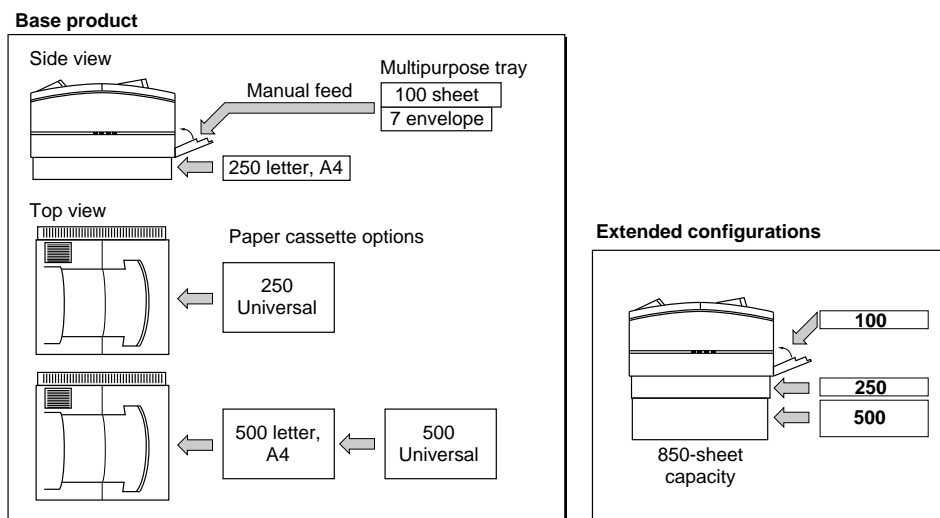

Status Lights

The LaserWriter 16/600 PS printer has four colored lights on the left side of the printer. These lights indicate what function the printer is performing or possible error conditions. Figure 1-8 shows a view of the status light symbols.

Figure 1-8 LaserWriter 16/600 PS status lights

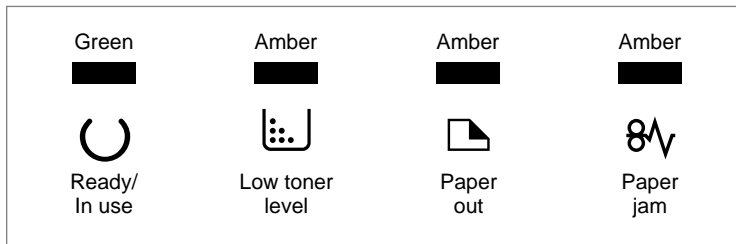

Table 1-7 describes the functions of the status lights.

Table 1-7 Status light functions

Light	Light's state	Printer's state
Ready/in use Green	On	The printer is ready to use.
	Off	The printer cannot print because there is an error condition, or because the printer cover is open.
	Flashing	The printer is warming up, or it is processing data for the next print job.
Low toner Amber	On	The toner in the printer is low or toner cartridge is not installed.
	Off	There is an adequate supply of toner in the printer.
Paper out Amber	On	The paper tray is empty, or it has been removed from the printer.
	Off	There is an adequate supply of paper in the paper tray.
	Flashing	The printer is in manual-feed mode and is ready for the next sheet of paper. The printer failed the startup test and requires service.
Paper jam Amber	On	There is a paper jam.
	Off	The paper is feeding correctly through the printer.
	Flashing	The printer requires service.

Introduction to the LaserWriter 16/600 PS Printer

Note

If there is an external hard disk attached to the printer, make sure the hard disk is powered on. Otherwise, the paper out and paper jam lights will flash alternately. If a hard disk is not attached to the printer, and the paper out and paper jam lights flash alternately, then the printer requires service. ♦

LaserWriter 16/600 PS Software

LaserWriter 16/600 PS Software

This chapter describes the LaserWriter 16/600 PS software. It includes

- an overview of the programming language, interpreter, driver, utility program, and page types
- descriptions of the software parameters that enable you to set up and configure the LaserWriter 16/600 PS printer, including page device parameters, product strings, interpreter parameters, and resource categories

Note

To use the information presented in this chapter you must be thoroughly familiar with the PostScript Level 2 programming language and have access to the information contained in the *PostScript Language Reference Manual Supplement* for Version 2014. ♦

Software Overview

This section provides an overview of the PostScript programming language, the PostScript interpreter, the printer driver, the printer utility program, and the page and envelope types supported by the printer.

Adobe PostScript Programming Language

The LaserWriter 16/600 PS printer executes descriptions written in the PostScript language. The version of the PostScript language used has features and capabilities that might not be present in other PostScript output devices. This developer note describes only the supplementary PostScript language features of the LaserWriter 16/600 PS printer. You should use this note in conjunction with the *PostScript Language Reference Manual*, second edition.

PostScript Interpreter

You may access the special features of the LaserWriter 16/600 PS printer by executing PostScript operators that exist only in this printer's interpreter. The PostScript interpreter version at the time of this printing is 2014.

The special operators are intended for use by interactive users, by programmers of host software that carries out user requests, or by users who may want to configure the LaserWriter 16/600 PS printer in nonstandard ways. Normally page descriptions should not refer to the special operators, since doing so impairs software portability.

Printer Driver

The LaserWriter 16/600 PS printer driver and Print Manager provide a general interface to the LaserWriter 16/600 PS printer. The interface should meet the needs of most Macintosh applications.

LaserWriter 16/600 PS Software

The printer driver

- provides full support for the PostScript Level 2 programming language
- supports multiple bins, a multipurpose paper tray, and an envelope feeder
- allows you to configure the driver according to your printer configuration
- enables the printer to report paper size in the standard and optional cassettes to the user
- presents error messages if they are reported back by the printer; for example, printer jam status or paper out
- supports optical density control through the video interface
- supports both TrueType and Type 1 fonts
- is compatible with version 7 of the Macintosh LaserWriter driver
- provides support for n-up printing, which is a new driver feature offered by version 8.0 of the LaserWriter driver that allows you to print one, two, or four logical pages on a single sheet of paper

Apple Printer Utility program

The Apple Printer Utility program, which is shipped with the LaserWriter 16/600 PS printer, allows you to control and configure the printer. Using the utility you can perform the following types of functions:

- set printer parameters, such as printer name, start page mode
- set printer density
- add or remove fonts and display or print a list of available fonts
- set page parameters and get the number of pages printed by the printer
- send PostScript files to the printer
- set imaging options, such as FinePrint and PhotoGrade
- set default communication parameters for each I/O port
- format an optional internal or external SCSI hard disk drive system for font storage

Page and Envelope Types

The page and envelope types for the LaserWriter 16/600 PS printer are listed in Table 2-3 on page 26. At the beginning of each job, the server selects the default paper tray, as assigned by the `defaultpapertray` operator. If the default is the main 250-sheet cassette, the server can detect its size and install the appropriate image region. If the default is the 50-sheet multipurpose tray, the server uses the image region most recently installed by the `setdefaultmultipurposetraysize` operator. When the multi-

LaserWriter 16/600 PS Software

purpose tray is selected in this way, or by using the `setpapertray` operator, it is treated like the main cassette. Up to 50 sheets of paper may be stacked in it, and it feeds continuously until it is empty, at which time the paper-out light comes on.

When a job requires a particular paper size, it invokes one of the paper tray selection operators listed in Table 2-1 before it generates an image. That paper tray selection stays in effect for the duration of the job. The server restores the default paper tray selection when that job is finished. Table 1-7, in Chapter 1, defines the different paper sizes.

If there is more than one paper source with the size of paper requested, the PostScript interpreter follows the `Priority` array from `InputAttributes` in the `setpagedevice` dictionary. The value of `Priority` is an array of integers. The first integer in the array represents the media source with the highest priority. When a `setpagedevice` request matches two or more media sources, `setpagedevice` chooses the one with the highest priority in the array of integers. If none of the matching sources appears in the array, `setpagedevice` chooses among them arbitrarily.

Table 2-1 Paper tray selection operators

Operator	Description
<code>a4tray</code>	Selects the paper tray containing A4-size paper and sets the page type to either <code>a4</code> or <code>a4small</code> , depending on the value of <code>pagetype</code> .
<code>a5tray</code>	Selects the paper tray containing A5-size paper and sets the page type to <code>a5</code> .
<code>b5tray</code>	Selects the paper tray containing B5-size paper and sets the page type to <code>b5</code> .
<code>c5tray</code>	Selects the paper tray containing C5-size paper and sets the page type to <code>c5</code> .
<code>com10tray</code>	Selects the paper tray containing COM10-size paper and sets the page type to <code>com10</code> .
<code>dltray</code>	Selects the paper tray containing DL-size paper and sets the page type to <code>dl</code> .
<code>legaltray</code>	Selects the paper tray containing legal-size paper and sets the page type to <code>legal</code> .
<code>lettertray</code>	Selects the paper tray containing letter-size paper and sets the page type to either <code>letter</code> or <code>lettersmall</code> , depending on the value of <code>pagetype</code> .
<code>monarchtray</code>	Selects the paper tray containing Monarch-size paper and sets the page type to <code>monarch</code> .

NOTE In all instances, a `rangecheck` error occurs if no matching paper tray is installed.

Device Setup

The PostScript language facilities set up the raster output device (printer) to fulfill the processing requirements of the page description. The `setpagedevice` operator performs the following device setup functions:

- It specifies processing requirements, such as making multiple copies or two-sided printing.
- It selects optional printer features, such as the proper input tray, paper size, and image area.
- It establishes device-dependent rendering parameters needed to produce output.
- It specifies default device setup or configuration parameters that may be used when the page description does not specify the parameters.

The `currentpagedevice` operator gets the current accumulated values and the adjusted state of the page device. The parameters for the `setpagedevice` operator are cumulative; that is, each new call to `setpagedevice` does not reset the state in total but modifies it. In addition, on each call to `setpagedevice`, the resulting accumulated page device state is processed by the interpreter so that the printer can produce the required results. This may cause further modification of the page device state.

The LaserWriter 16/600 PS printer uses the PostScript Level 2 implementation, which provides device control operators defined in the special dictionary `statusdict`.

For more information about how the `setpagedevice` operator specifies the processing requirements of a document, refer to Section 4.11 of the *PostScript Language Reference Manual*, second edition.

Page Device Parameters

This section describes the page device parameters present in the LaserWriter 16/600 PS printer. Refer to the *PostScript Language Reference Manual*, Section 4.11.3, for supplemental information on parameter semantics. Table 2-2 lists the page device parameters and their defaults, and provides additional technical information.

Table 2-2 Page device parameters

Key	Type	Default	Description
BeginPage	<i>procedure</i>	{pop}	This procedure is executed at the beginning of each page. A BeginPage procedure occurs at the end of <code>setpagedevice</code> , at the end of <code>showpage</code> or <code>copypage</code> , and during any operation that reinstates a page device different from the existing one.
EndPage	<i>procedure</i>	{exch pop 2 ne}	This procedure is executed at the end of each page. An EndPage procedure occurs at the beginning of each <code>showpage</code> or <code>copypage</code> , and when the current page device is about to be replaced by a different page device.
ExitJamRecovery	<i>boolean</i>	false	If the value of this parameter is <code>true</code> , pages that jam in the exit path are reprinted. If the value of this parameter is <code>false</code> (jam recovery disabled), pages that jam are not reprinted. In this case, performance may be improved because it is possible to overlap more page processing. Value persists across power cycles.
FaxOptions	<i>dictionary</i>		This dictionary contains parameters that direct fax transmissions from a PostScript language program. Refer to "Fax Parameters" on page 29 for further information about FaxOptions defaults and the keys found in this dictionary.
HWResolution	<i>array</i>	[600 600]	This parameter controls the resolution of the output.
ImagingBBox	<i>array or null</i>	null	This parameter is an optional bounding box. If not <code>null</code> , the value is an array of four numbers in the default user coordinate system stating lower-left <i>x</i> , lower-left <i>y</i> , upper-right <i>x</i> , and upper-right <i>y</i> of the page image bounding box. When a PostScript program specifies an ImagingBBox, it asserts that it will not paint any marks outside the rectangle. However, any marks that fall outside the rectangle may still be painted.

continued

Table 2-2 Page device parameters (continued)

Key	Type	Default	Description
InputAttributes	<i>dictionary</i>	Depends on configuration	This dictionary contains an entry for each source of input media available for the printer. The values <i>x</i> and <i>y</i> depend on which paper tray is installed. The 50-sheet manual feeder and 250-sheet universal cassette are always present. However, if an optional paper cassette is installed but missing, the corresponding entry in the InputAttributes dictionary is set to null. This can happen only when the printer is turned on and the tray is not installed. If a job is sent to the printer and the tray is removed, the PostScript interpreter assumes a tray of the same size will be installed and sets the attributes accordingly. If a different tray is installed, the attributes change to reflect the characteristics of the new tray. There are values of matching tolerance for the PageSize parameter. See PageSize later in this table.
Install	<i>procedure</i>		<p>This procedure installs values in the graphics state during each call to setpagedevice. The setpagedevice operator calls this procedure after setting up the device and installing it as the current device in the graphics state, but before executing the implicit erasepage and initgraphics operators.</p> <p>The default install procedure is:</p> <pre> { currentpagedevice /PreRenderingDetails get dup /DefaultHalftone get exch /ActualPreRenderingEnhance get not { -dict- exch 2 copy known { get }{ exch pop } ifelse } if /Halftone findresource sethalftone {} settransfer false setstrokeadjust /DefaultColorRendering /ColorRendering findresource setcolorrendering } </pre>
ManualFeed	<i>boolean</i>	false	The value of this parameter determines whether the input medium (paper, and so on) is to be drawn from the manual or the automatic feeder. The value of this parameter is true for manual feeding, and false for automatic feeding.

continued

Table 2-2 Page device parameters (continued)

Key	Type	Default	Description
ManualFeedTimeout	<i>integer</i>	60	This parameter specifies the number of seconds the printer will wait for a page to be fed manually before generating a timeout error. The default is 60 seconds. If the value is set to 0, there is no timeout, and the printer waits infinitely. Value persists across power cycles.
Margins	<i>array</i>	[0 0]	This parameter is an array of two numbers that relocate the page image on the media by <i>x</i> units in the direction of the <i>x</i> coordinate, and <i>y</i> units in the direction of the <i>y</i> coordinate. The <i>x</i> and <i>y</i> values are expressed as 1/300 of an inch, or 1/600 of an inch, depending on the resolution. Value persists across power cycles.
MediaColor	<i>string</i> or <i>null</i>	null	This parameter specifies the color of the input media.
MediaType	<i>string</i> or <i>null</i>	null	This parameter specifies the type of media, paper, transparency, and so on.
MediaWeight	<i>number</i> or <i>null</i>	null	This parameter specifies the weight of the media.
NumCopies	<i>integer</i> or <i>null</i>	null	If the value of this parameter is not <i>null</i> , it specifies the number of copies to produce. The value applies to each individual page, or to the entire document, depending on the setting of <i>Collate</i> . If the value of <i>NumCopies</i> is <i>null</i> , <i>showpage</i> and <i>copypage</i> should consult the value of <i>#copies</i> in the current dictionary stack each time they are executed.
OutputDevice	<i>name</i>	/Printer	This parameter specifies which communications device is to be used for <i>stdout</i> and <i>stderr</i> .
OutputFaceUp	<i>boolean</i>	false	The value of this parameter determines whether the printed pages are output face up or face down in the output tray. If the value is <i>false</i> , the pages are output face up. If the value is <i>true</i> , the pages are output face down. The value persists across power cycles.

continued

Table 2-2 Page device parameters (continued)

Key	Type	Default	Description
OutputPage	<i>boolean</i>	true	If the value of this parameter is <code>true</code> , pages are printed normally, and output into the output tray. If the value is <code>false</code> , no pages are actually printed. However, all other processing is done as if the pages were to be printed, including rasterizing to a frame buffer. In this case, the time required to process a page includes everything except the time spent waiting for the marking engine. In addition, rasterization occurs synchronously with the execution of <code>showpage</code> instead of being overlapped with the execution of subsequent pages. This function measures the cost in time of executing a page.
PageSize	<i>array</i>	Depends on configuration	This parameter defines the overall page size that was assumed during generation of the page description. The <code>PageSize</code> parameter is an array of two numbers [<code>width height</code>], that specify the overall size of the page including borders. Matching tolerance is 5 default user space units in either dimension. Landscape mode ([792 612]) is also valid.
Policies	<i>dictionary</i>		This dictionary contains feature-policy pairs that specify what <code>setpagedevice</code> should do when a feature request cannot be satisfied. The default procedure is: <pre><</PolicyNotFound 1 /PageSize 0 /PolicyReport {pop}>> /ProcessColorModle 0 /OutputDevice 0</pre>
PostRendering Enhance	<i>boolean</i>	false	If the value of this parameter is <code>true</code> , product-specific image enhancements are enabled. These enhancements are made after the page is rasterized in memory. The value persists across power cycles.
PostRendering EnhanceDetails	<i>dictionary</i>		This dictionary describes product-specific details related to the post-rendering image enhancement. Refer to “Details Dictionary” on page 35 for further information.

continued

Table 2-2 Page device parameters (continued)

Key	Type	Default	Description
PreRenderingEnhance	<i>boolean</i>	true	If the value of this parameter is <code>true</code> , product-specific image enhancements are enabled. These enhancements are made before the image is rasterized into memory. The <code>PreRenderingEnhance</code> parameter in the page device dictionary is treated as a hint rather than an assertion. If there is not sufficient memory to create an enhanced frame buffer of the requested size, this parameter is treated as an unsatisfied request to be handled by the <code>Policies</code> dictionary. Value persists across power cycles.
PreRenderingEnhanceDetails	<i>dictionary</i>	Hardware dependent	This dictionary describes product-specific details related to the pre-rendering image enhancement. Refer to “Details Dictionary” on page 35 later in this chapter for further information.
TraySwitch	<i>boolean</i>	false	If the value of this parameter is <code>true</code> , automatic tray switching is provided. When one tray runs out of paper, the printer switches to another tray containing the same type of medium, without alerting you that the printer has run out of paper.

NOTE All the terms in column 1, for example `PostRenderingEnhanceDetails`, are one word. They may be split in this table because of column width restrictions.

Table 2-3 lists the different page sizes. Page size is indicated by an array of two numbers ([595 842]) that indicate width and height. The units are equivalent to 1/72 of an inch.

Table 2-3 Paper sizes

Paper size	Name
[595 842]	A4
[420 595]	A5
[516 728]	B5
[459 649]	C5 envelope
[297 684]	COM10 envelope
[312 624]	DL envelope
[612 1008]	Legal
[612 792]	Letter
[279 540]	Monarch envelope

Table 2-4 lists the paper-tray slot numbers and corresponding input sources.

Table 2-4 Paper tray slot numbers and input sources

Slot number	Input source
0	Cassette (250 sheets)
1	Multipurpose tray (50 sheets)
2	Cassette (500 sheets)
3	Envelope feeder

Page Device Parameters for /FaxReceived Devices

Table 2-5 lists the page device parameters for a /FaxReceived device. The table lists only the key, type, and default value for a /FaxReceived page device. The descriptions for these page device parameters are the same as those provided in Table 2-2, unless otherwise noted.

Table 2-5 Page device parameters for a /FaxReceived device

Key	Type	Default
ExitJamRecovery	<i>boolean</i>	true
HWResolution	<i>array</i>	[600 600]
ImagingBBox	<i>array or null</i>	null
InputAttributes	<i>dictionary</i>	null
Install	<i>procedure</i>	The install procedure for a /FaxReceived device is the same as the install procedure described on page 23 for page devices.
ManualFeed	<i>boolean</i>	false
ManualFeedTimeout	<i>integer</i>	null
Margins	<i>array or null</i>	null
MediaColor	<i>string or null</i>	null
MediaType	<i>string or null</i>	null
MediaWeight	<i>number or null</i>	null
NumCopies	<i>integer or null</i>	null
OutputDevice	<i>name</i>	/FaxReceived
OutputFaceUp	<i>boolean</i>	false
OutputPage	<i>boolean</i>	null
PageSize	<i>array</i>	[612 792]

Page Device Parameters for /Fax devices

Table 2-6 lists the page device parameters for a /Fax device. The table lists only the key, type, and default value for a /Fax page device. The descriptions for these page device parameters are the same as those provided in Table 2-2, unless otherwise noted.

Table 2-6 Page device parameters for a /Fax device

Key	Type	Default
ExitJamRecovery	<i>boolean</i>	true
FaxOptions	<i>dictionary</i>	See "Fax Parameters" beginning on page 29.
HWResolution	<i>array</i>	[200 200]
ImagingBBox	<i>array or null</i>	null
InputAttributes	<i>dictionary</i>	null
Install	<i>procedure</i>	The install procedure for a /Fax device is as follows:
		<pre> /faxinstall { % halftone: << /HalftoneType 1 currentpagedevice /FaxOptions get /FaxType get dup type /nulltype eq { pop (%Fax%) currentdevparams /DefaultResolution get } if 1 eq {/Frequency 50}{/Frequency 25} ifelse /Angle 45 /SpotFunction { abs exch abs 2 copy add 1 qt {1 sub dup mul exch 1 sub dup mul add 1 sub} {dup mul exch dup mul add 1 exch sub} ifelse } >> sethalftone % transfer function: {} settransfer % stroke adjustment: false setstrokeadjust % color rendering: /DefaultColorRendering /ColorRendering findresource set colorrendering /FaxOps /ProcSet findresource begin /internalfaxinstall faxopsexec end } </pre>
ManualFeed	<i>boolean</i>	false
MediaColor	<i>string or null</i>	null
MediaType	<i>string or null</i>	null
MediaWeight	<i>number or null</i>	null

continued

Table 2-6 Page device parameters for a /Fax device (continued)

Key	Type	Default
NumCopies	<i>integer or null</i>	null
OutputDevice	<i>name</i>	/Fax
OutputPage	<i>boolean</i>	true
PageSize	<i>array</i>	[612 792]

Fax Parameters

PostScript language drivers create pages that can be printed or faxed. If you intend to build PostScript language drivers and utility software to work with PostScript fax printers, you will need the information about fax parameters contained in the FaxOptions dictionary, and listed in Table 2-5.

Table 2-7 Parameters for the FaxOptions dictionary

Key	Type	Default	Description
CalleePhone	<i>string or null</i>	null	Indicates the telephone number of the fax machine to which the call is being directed. The value of CalleePhone is used for Confirmation, CoverSheet, and PageCaption procedures. It differs from DialCallee in that it omits or alters routing prefixes and suffixes. Compare the following versions of a Swiss phone number with the version shown under DialCallee on page 31. (0041-5-55-55-55732) or (CH 5-55-55-55732) If the value of CalleePhone is null, the value of DialCallee is used.
CallerID	<i>string or null</i>	null	This ID is defined by the CCITT (1988) fax protocol. It is a string of up to 20 characters which the caller uses to identify himself to the callee. If the value of CallerID is null, then the value of the ID from the %Fax% device parameter set is used. If this device parameter is not set, the string returned by the system parameter PrinterName is used. If this string is greater than 20 characters, the 20 leftmost characters are used.
CallerPhone	<i>string or null</i>	null	Indicates the telephone number of the caller's fax machine.

continued

Table 2-7 Parameters for the FaxOptions dictionary (continued)

Key	Type	Default	Description
Confirmation	<i>procedure or null</i>	See description	<p>Prints a confirmation sheet on the print mechanism at the sending end. The Confirmation procedure is executed when the fax job is finished and the transmission is completed. You can omit the confirmation report by setting the value of this parameter to null. You can also customize the report using your own procedure.</p> <p>You should set the value of this parameter to null if the %Fax% parameter DefaultConfirmOn is false, otherwise the default value is {DefaultConfirmationOn faxopsexec}.</p>
Copies	<i>array of dictionaries or null</i>	null	<p>Enables you to broadcast the same raster or PostScript language file to multiple recipients. The only keys allowed in these dictionaries are the ones allowed in the FaxOptions dictionary and listed in this table. If the same key is defined in both dictionaries, the value from Copies takes precedence.</p>
CoverNote	<i>array of strings or null</i>	null	<p>Passes information to the CoverSheet procedure. It may also be used for the entire fax message if the message consists only of the cover sheet.</p>
CoverSheet	<i>procedure or null</i>	See description	<p>Allows you to define CoverSheet as a PostScript language procedure that produces a customized cover sheet. When this parameter is null, the software does not generate cover sheets.</p> <p>The default value is null if the %Fax% parameter DefaultCoversOn is false. Otherwise, the default value is {/DefaultCoverSheet faxopsecec}.</p>
CoverSheetOnly	<i>boolean</i>	false	<p>Indicates that it is all right to send an empty job (cover sheet only). If the <i>boolean</i> value is false and the PostScript language job produces no pages, no phone call is made and nothing is sent. If the <i>boolean</i> value is true and the value of CoverSheet is not null, then the page generated by the cover sheet procedure is sent in any case.</p>
HostJobID	<i>integer</i>	0	

continued

Table 2-7 Parameters for the `FaxOptions` dictionary (continued)

Key	Type	Default	Description
<code>DialCallee</code>	<i>string</i>	<code>null</code>	<p>Indicates the phone number of the fax machine to which the call is being directed. The string is sent to the telephone auto-dialer in the fax printer. It consists of a sequence of the following characters:</p> <ul style="list-style-type: none"> P Begin dialing T Begin DTMF (touch-tone) dialing 0-9 Send signal digit to telephone exchange *# Send DTMF symbol to telephone exchange , Pause for 2 seconds W Wait for dial tone <p>The auto-dialer ignores any other characters.</p> <p>This string contains a maximum of 100 characters. The following string represents a Swiss phone number preceded by the routing prefix T and the suffix #:</p> <p>T9,011-41-5-55-55-55732#</p>
<code>ErrorCorrect</code>	<i>boolean</i>	<code>true</code>	<p>Decides whether or not error correction should be attempted for the transmission. If the receiving machine does not have the error correction facility, the transmission takes place without it.</p>
<code>FaxType</code>	<i>integer or null</i>	<code>null</code>	<p>Decides how the actual page contents are prepared and transmitted. If the value is an integer, it should be 0 or 1:</p> <ul style="list-style-type: none"> 0 Use standard CCITT group 3 resolution 1 Use fine CCITT group 3 resolution <p>If the <code>FaxType</code> is 0, the transmitted <i>y</i> resolution of the fax is approximately 100 lines per inch. If <code>FaxType</code> is 1, the <i>y</i> resolution is doubled, and transmission time is correspondingly longer. If the <code>FaxType</code> is <code>null</code>, the value of the <code>%Fax%</code> device parameter, <code>DefaultResolution</code> (1 or 0), selects the resolution.</p>

continued

Table 2-7 Parameters for the FaxOptions dictionary (continued)

Key	Type	Default	Description																					
MailingTime	<i>array of integers or null</i>	null	Indicates when the fax message should be transmitted. The value of this parameter is an array of integers with the following entries: <table border="1"> <thead> <tr> <th>Index</th> <th>Values</th> <th>Meaning</th> </tr> </thead> <tbody> <tr> <td>0</td> <td>[1980-2079]</td> <td>Year</td> </tr> <tr> <td>1</td> <td>[1-12]</td> <td>Month</td> </tr> <tr> <td>2</td> <td>[1-31]</td> <td>Day</td> </tr> <tr> <td>3</td> <td>[0-23]</td> <td>Hour</td> </tr> <tr> <td>4</td> <td>[0-59]</td> <td>Minute</td> </tr> <tr> <td>5</td> <td>[0-59]</td> <td>Second</td> </tr> </tbody> </table> <p>If the value is null, the message is sent immediately.</p>	Index	Values	Meaning	0	[1980-2079]	Year	1	[1-12]	Month	2	[1-31]	Day	3	[0-23]	Hour	4	[0-59]	Minute	5	[0-59]	Second
Index	Values	Meaning																						
0	[1980-2079]	Year																						
1	[1-12]	Month																						
2	[1-31]	Day																						
3	[0-23]	Hour																						
4	[0-59]	Minute																						
5	[0-59]	Second																						
MaxRetries	<i>integer or null</i>	null	Indicates how many additional times (after the first time) the machine should try to send the fax message before giving up on transmission. The maximum value is 100. If the value of this parameter is null, the value provided by the %Fax% parameter DefaultRetryCount is used.																					
nPages	<i>integer or null</i>	null	Supplies the application's estimate of page count, exclusive of automatically generated cover sheets. If transmission starts before the transmitting machine has finished processing the job, the number of pages is not known to the printer and it uses the value supplied by nPages. If the value of nPages is null, the cover sheet lists an unknown number of pages.																					
PageCaption	<i>procedure or null</i>	See description	Generates a page caption for the cover sheet with information such as sender's name, recipient, and so on. The caption will not be generated if the value is null. <p>The value of this parameter is null if the %Fax% parameter DefaultCaptionOn is false, otherwise the default value is {DefaultPageCaption faxopsexec}.</p>																					
PostScript Password	<i>string or null</i>	null	Specifies the password to be used to gain permission from the machine being called to transmit the fax job as a PostScript language file. The default is null, which means that no password is used.																					

continued

Table 2-7 Parameters for the FaxOptions dictionary (continued)

Key	Type	Default	Description
ProcInfo	<i>dictionary or null</i>	null	Supplies any number of additional application-specific key-value pairs. The key-value pairs convey variable information for cover sheets, confirmation reports, and page captions.
RecipientID	<i>string or null</i>	null	Contains a string that uniquely identifies the individual within an organization to whom the fax message is addressed. This ID may be read only by a computer. This ID enables subsequent delivery of the fax message within the recipient's organization. If the value of this parameter is null, a string of nulls is transmitted.
RecipientLanguage	<i>string or null</i>	null	
RecipientMailStop	<i>string or null</i>	null	Contains information needed for hand delivery of the fax message, including mail stop, building number, and so on.
RecipientName	<i>string or null</i>	null	Provides the name of the person to whom the fax is being sent. If there is a default value for RecipientName, the code seeks alternative non-null values to store in the job log, looking at the following items in the order shown. Each time the code finds a default value, it goes to the next parameter on the list: <ul style="list-style-type: none"> ■ RecipientOrg ■ CalleePhone ■ DialCallee
RecipientOrg	<i>string or null</i>	null	Indicates the name of the company and organization of the person receiving the fax message. If the code finds a default value, it falls back to both of the following: <ul style="list-style-type: none"> ■ CalleePhone ■ DialCallee
RecipientPhone	<i>string or null</i>	null	Indicates the voice-phone number of the person to whom the fax message is being sent. It is not the same as DialCallee, which is the fax number. The RecipientPhone parameter generates custom cover sheets that provide routing information for the fax attendant. If the code finds a default value, it falls back to both of the following: <ul style="list-style-type: none"> ■ CalleePhone ■ DialCallee

continued

Table 2-7 Parameters for the FaxOptions dictionary (continued)

Key	Type	Default	Description
Regarding	<i>string or null</i>	null	Passes information to the CoverSheet procedure. This string is used typically to add a subject line to the cover sheet.
RetryInterval	<i>string or null</i>	null	This parameter is a positive integer that specifies the number of minutes to wait before trying to resend a fax that failed. The maximum value of this parameter is 60, indicating 60 minutes. If the value is null, the length of the retry interval is determined by the %Fax% device parameter DefaultRetryInterval.
RevertToRaster	<i>boolean</i>	true	Used by the faxsendops operator to decide what to do when the receiving machine refuses to accept a PostScript language transmission. If the value of this parameter is true, the PostScript language job is imaged locally and a rasterized fax transmission is made. If the value is false, the job will fail.
SenderID	<i>string or null</i>	null	Contains a string that uniquely identifies the sender.
SenderMailStop	<i>string or null</i>	null	Contains information such as the sender's mail stop and building number. It facilitates hand delivery of return fax messages.
SenderName	<i>string or null</i>	null	Provides the name of the sender. If the code finds a null value for SenderName, it seeks an alternative non-null value to store in the job log. The fall back order is shown below: <ul style="list-style-type: none"> ■ SenderOrg ■ CallerID If both parameters contain null values, the value of the %Fax% device parameter ID is used.
SenderOrg	<i>string or null</i>	null	Indicates the sender's company or organization name. If the code finds a null value for SenderOrg, it seeks an alternative non-null value to store in the job log, and uses the value of SenderOrg. If the value of SenderOrg is null, the value of the %Fax% device parameter ID is used.
SenderPhone	<i>string or null</i>	null	Indicates the sender's voice-phone number.

continued

Table 2-7 Parameters for the `FaxOptions` dictionary (continued)

Key	Type	Default	Description
<code>TrimWhite</code>	<i>boolean</i>	<code>false</code>	Determines the size of the white space at the top and bottom of pages. If the value of this parameter is <code>true</code> when the fax raster transmission is being prepared, the white space at the top and bottom is removed before the pages are transmitted. This results in shorter phone calls, but also results in a mixture of page lengths.

NOTE All the terms in column 1, for example `RecipientLanguage`, are one word. They may be split in this table because of column width restrictions.

Details Dictionary

Certain page device features have many variables that decide how the features function. These variables are different on different products. The feature is enabled or disabled by a primary page device entry. However, the exact way in which the feature functions is decided by secondary entries in a `Details` dictionary page device entry. This means an application that is not knowledgeable about the details of the feature can enable and disable the feature, while more sophisticated utilities configure the details separately. Section 2.1 of the *PostScript Language Reference Manual Supplement* provides more information on this subject.

Product Strings

The LaserWriter 16/600 PS printer's strings contain characters that provide information about the printer and the printer software. Table 2-8 lists values assigned to the LaserWriter 16/600 PS product strings.

Table 2-8 Product string values

String name	Type	Value	Definition
<code>languagelevel</code>	<i>integer</i>	2	Level of the PostScript language
<code>product</code>	<i>string</i>	LaserWriter	Product name
<code>revision</code>	<i>integer</i>	1	Current revision level of the printer
<code>serialnumber</code>	<i>integer</i>	Depends on the individual printer	Serial number of the printer
<code>version</code>	<i>string</i>	2014.106	Version of the PostScript language

NOTE The `version` suffix (112) is the current version. This may be updated in printers that ship later.

Interpreter Parameters

Certain parameters control the operation and behavior of the PostScript interpreter. Many of them are connected with memory allocation and other specific-purpose resources. For instance, interpreter parameters control the maximum amount of memory allocated to virtual memory, font cache, and halftone screens.

The LaserWriter 16/600 PS printer is configured initially with interpreter parameter values appropriate for most applications. However, using a PostScript language program, you can alter the interpreter parameters to favor certain applications, or to adapt the printer to special requirements. There are three classes of interpreter parameters: user, system, and device. There are several types of device parameters, including communications, parallel port, engine, and emulator parameters.

Each class has a PostScript language operator to read the parameter values and an operator to set parameter values. There are six resulting operators: `currentuserparams`, `setuserparams`, `currentsystemparams`, `setsystemparams`, `currentdevparams`, and `setdevparams`.

You will find information on parameter semantics in the *PostScript Language Reference Manual*, second edition.

User Parameters

Within reasonable limits, you can change user parameters without special authorization or password, using any PostScript Language program. User parameters establish temporary policies on issues such as size limits and inserting new items into caches.

The `setuserparams` operator sets user parameters, and the `currentuserparams` operator reads their current values. Unless otherwise indicated, all user parameters are subject to `save` and `restore` boundaries. The `restore` operator resets all user parameters to their values at the time of the matching `save`. The initial value of the user parameters when the printer is turned on for the first time depends on the product. Table 2-9 lists the user parameters present in the LaserWriter 16/600 PS printer. You can find further information on these parameters in the *PostScript Language Reference Manual*, second edition, and the *PostScript Language Reference Manual Supplement*.

Table 2-9 User parameters in the LaserWriter 16/600 PS printer

Key	Type	Default	Description
AccurateScreens	<i>boolean</i>	false	An optional parameter. If the value of this parameter is <code>true</code> , it invokes a special halftone algorithm that is extremely precise, but requires a lot of computation.
JobName	<i>string</i>	()	Establishes <i>string</i> as the name of the current job. It should contain no more than 32 characters.
JobTimeout	<i>integer</i>	0	Sets the number of seconds a job is allowed to run before it is aborted and a <code>timeout</code> error is generated. This parameter may be any number larger than 0. If you set this parameter to 0, timeout is disabled.
MaxDictStack	<i>integer</i>	530	Determines the maximum number of elements in the dictionary stack. This parameter may be set to 0 or any number larger than 0.
MaxExecStack	<i>integer</i>	10015	Determines the maximum number of elements in the execution stack. This parameter may be set to 0 or any number larger than 0.
MaxFontItem	<i>integer</i>	12500	Determines the maximum number of bytes occupied by the pixel array of a single character in the font cache. This parameter may be set to 0 or any number larger than 0.
MaxFormItem	<i>integer</i>	100000	Determines the number of bytes occupied by a single cached character. This parameter may be set to 0 or any number larger than 0.
MaxLocalVM	<i>integer</i>	2147483647	Determines the maximum number of bytes occupied by values in local virtual memory. This parameter may be set to 0 or any number larger than 0.
MaxOpStack	<i>integer</i>	100000	Determines the maximum number of elements in the operand stack. This parameter may be set to 0 or any number larger than 0.
MaxPatternItem	<i>integer</i>	20000	Determines the maximum number of bytes occupied by a single cached pattern. This parameter may be set to 0 or any number larger than 0.
MaxScreenItem	<i>integer</i>	48000	Determines the maximum number of bytes occupied by a single halftone screen. This parameter may be set to 0 or any number larger than 0.

continued

Table 2-9 User parameters in the LaserWriter 16/600 PS printer (continued)

Key	Type	Default	Description
MaxUPathItem	<i>integer</i>	5000	Determines the maximum number of bytes occupied by a single cached user path. This parameter may be set to 0 or any number larger than 0.
MinFontCompress	<i>integer</i>	1250	Sets the threshold at which a cached character is stored in compressed form instead of as a full pixel array. This parameter may be set to 0 or any number larger than 0.
VMReclaim	<i>integer</i>	0	Enables or disables local garbage collection. <ul style="list-style-type: none"> ■ 0 Enables automatic collection ■ -1 Disables local garbage collection for VM ■ -2 Disables both local and global garbage collection for VM.
VMThreshold	<i>integer</i>	40000	This is the frequency of garbage collection. Collection is triggered whenever the number of bytes indicated by the parameter setting has been allocated. This parameter may be set to 0 or any number larger than 0.
WaitTimeout	<i>integer</i>	40	Indicates the current wait timeout, which is the number of seconds the interpreter waits to receive additional characters from the host before it aborts the current job by executing a timeout error. This parameter may be set to 0 or any number larger than 0.

System Parameters

System parameters alter the overall configuration of the printer. You can set system parameters using the `setssystemparams` operator and read them using the `currentssystemparams` operator. You must use a password to change system parameters. System parameters are not subject to `save` and `restore`. Their values persist across jobs and may persist across power cycles. Table 2-10 lists the system parameters present in the LaserWriter 16/600 PS printer.

Note

For further information about parameters listed in Table 2-10, refer to the *PostScript Language Reference Manual Supplement*, Section 3.4 and Section 3.9. ♦

Table 2-10 System parameters in the LaserWriter 16/600 PS printer

Key	Type	Default	Description
BuildTime	<i>integer</i>	776409784	This is a time stamp that identifies the date the PostScript interpreter was built. This is a read-only parameter.
ByteOrder	<i>boolean</i>	false	Determines the order of multiple-byte numbers in binary-encoded tokens: <i>false</i> indicates high-order byte first, <i>true</i> indicates low-order byte first.
CurDisplayList	<i>integer</i>	0	Identifies the amount of RAM currently occupied by the display list. This is a read-only parameter.
CurFontCache	<i>integer</i>	0	Identifies the amount of RAM currently occupied by the font cache. This is a read-only parameter.
CurFormCache	<i>integer</i>	0	Identifies the amount of RAM currently occupied by the form cache. This is a read-only parameter.
CurInputDevice	<i>string</i>	()	Indicates the name of the communications device that corresponds to the current input file for the PostScript language program currently being executed. This is a read-only parameter.
CurOutlineCache	<i>integer</i>	0	Identifies the amount of RAM currently occupied by the outline cache. This is a read-only parameter.
CurOutputDevice	<i>string</i>	()	Indicates the name of the communications device that corresponds to the current output file for the PostScript language program currently being executed. This is a read-only parameter.
CurPatternCache	<i>integer</i>	0	Identifies the amount of RAM currently occupied by the pattern cache. Indicates the name of the communications device that corresponds to the current input file for the PostScript language program currently being executed. This is a read-only parameter.

continued

Table 2-10 System parameters in the LaserWriter 16/600 PS printer (continued)

Key	Type	Default	Description
CurScreenStorage	<i>integer</i>	0	Identifies the amount of RAM currently occupied by screen storage. Indicates the name of the communications device that corresponds to the current input file for the PostScript language program currently being executed. This is a read-only parameter.
CurSourceList	<i>integer</i>	0	Indicates the number of bytes currently occupied by source lists. This is a read-only parameter and may be set to 0 or any number larger than 0.
CurStoredScreenCache	<i>integer</i>	0	Indicates the number of bytes currently used for screen files on the storage device. This number includes currently active screens.
CurUPathCache	<i>integer</i>	0	Indicates the number of bytes currently occupied by the U path cache. This is a read-only parameter and may be set to 0 or any number larger than 0.
DoStartPage	<i>boolean</i>	true	Indicates whether or not the start page should print during system initialization. The start page prints if the value is true. Value is persistent across power cycles.
FactoryDefaults	<i>boolean</i>	false	This parameter is generally false. However, if you set the parameter to true and immediately turn off the printer, all nonvolatile parameters will revert to the factory default values the next time the printer is turned on.
FatalErrorAddress	<i>integer</i>	0	This integer is the hardware address of the last call to the fatal error handler. A non-zero value for this parameter indicates that a fatal system error occurred earlier.
FontResourceDir	<i>string</i>	(fonts/)	Controls the location of external fonts, which are resources in PostScript Level 2.
GenericResourceDir	<i>string</i>	(Resource/)	Controls the location of external resources for the Generic category and all other categories based upon it.

continued

Table 2-10 System parameters in the LaserWriter 16/600 PS printer (continued)

Key	Type	Default	Description
GenericResourcePathSep	<i>string</i>	(/)	Used in conjunction with <code>GenericResourceDir</code> to control the location of external resources for the <code>Generic</code> category and all other categories based upon it. With <code>GenericResourceDir</code> as <code>(Resource/)</code> , and <code>GenericResourcePathSep</code> as <code>(/)</code> , the <code>AdobeLogo</code> resource of the <code>Pattern</code> category would be in <code>Resource/Pattern/AdobeLogo</code> .
JobTimeout	<i>integer</i>	0	Indicates the value in seconds to which the user parameter <code>JobTimeout</code> is initialized at the beginning of each job. This parameter may be set to 0 or any number larger than 0.
LicenseID	<i>string</i>	(LN-001-013)	Contains the Adobe-assigned license identification. This value is unique to each printer. Any string of non-null characters is legal.
MaxDisplayList	<i>integer</i>	Function of RAM size	Indicates the maximum number of bytes occupied by display lists, excluding those held in caches. Initial value is 4% of installed RAM. This number is recomputed when the RAM configuration changes. This parameter may be set to 0 or any number larger than 0.
MaxFontCache	<i>integer</i>	Function of RAM size	Indicates the maximum number of bytes occupied by the font cache. Initial value is based on the amount of RAM installed. The value is 167,772 bytes for 4 MB RAM. Otherwise, the value is 10% of installed RAM. This number is recomputed when the RAM configuration changes.
MaxFormCache	<i>integer</i>	100000	Indicates the maximum number of bytes occupied by the form cache. This parameter may be set to 0 or any number larger than 0.

continued

Table 2-10 System parameters in the LaserWriter 16/600 PS printer (continued)

Key	Type	Default	Description
MaxImageBuffer	<i>integer</i>	65536	Indicates the maximum number of bytes that can be used for a single image buffer. The image buffer holds an internal data representation for sampled image source data. The interpreter may round the value if the value requested is out of range.
MaxOutlineCache	<i>integer</i>	65536	Indicates the maximum number of bytes occupied by cached character outlines (<code>CharStrings</code>) for fonts whose definitions are kept on disk instead of in VM. This parameter may be set to 0 or any number larger than 0.
MaxPatternCache	<i>integer</i>	100000	Indicates the maximum number of bytes occupied by the pattern cache. This parameter may be set to 0 or any number larger than 0.
MaxRasterMemory	<i>integer</i>	0	Indicates the largest amount of memory, in bytes, that may be allocated to the frame buffer. A value of 0 indicates that enough memory should be reserved for the largest achievable frame buffer. The implementation ignores values that are too small, and guarantees that an <code>a4small</code> , <code>lettersmall</code> , or <code>b5</code> size frame buffer can be allocated. This parameter may be set to 0 or any number larger than 0.
MaxScreenStorage	<i>integer</i>	Function of RAM size	Indicates the maximum number of bytes occupied by all active halftone screens. Initial value is 30,000 bytes per MB of RAM installed, up to a maximum of 120,000 bytes. This number is recomputed when the RAM configuration changes. This parameter may be set to 0 or any number larger than 0.
MaxSourceList	<i>integer</i>	24576	Indicates the maximum number of bytes that can be used by source lists. This parameter may be set to 0 or any number larger than 0.
MaxUPathCache	<i>integer</i>	300000	Indicates the maximum number of bytes occupied by the user path. This parameter may be set to 0 or any number larger than 0.

continued

Table 2-10 System parameters in the LaserWriter 16/600 PS printer (continued)

Key	Type	Default	Description
PageCount	<i>integer</i>	0	Indicates how many pages have been successfully printed since manufacture. This is a read-only parameter.
PrinterMode	<i>integer</i>	0	Indicates the position of the printer's configuration switch. The value is 0 when the switch points down and 1 when it points up.
PrinterName	<i>string</i>	(LaserWriter 16/600 PS)	Establishes <i>string</i> as the current name of the printer. You may set this parameter to any string of 32 or fewer characters. The colon (:) and the at symbol (@) are not allowed.
RamSize	<i>integer</i>	Function of RAM size	Indicates in bytes the amount of the RAM installed in the printer. This is a read-only parameter. The LaserWriter 16/600 PS printer is initially configured with 8 MB of RAM. A total of 32 MB can be installed.
RealFormat	<i>string</i>	IEEE	Native representation of real numbers in binary encoded tokens.
Revision	<i>integer</i>	1	Designates the current revision level of the ROM in which the interpreter is running. This is a read-only parameter.
StartJobPassword	<i>string</i>	()	This write-only password authorizes the use of the <code>start job</code> operator. Any string of 32 or fewer characters may be used.
StartupMode	<i>integer</i>	1	Controls whether the system start file or some other startup procedure should be executed during system initialization. If the value of this parameter is 0, there are no special startup procedures. Other values may be used that are product specific, and they result in product-dependent startup procedures.
SystemParamsPassword	<i>string</i>	()	This write-only password authorizes the use of the <code>setsystemparams</code> and <code>setdevparams</code> operators. Any string of 32 or fewer characters may be used. Value is persistent across power cycles.

continued

Table 2-10 System parameters in the LaserWriter 16/600 PS printer (continued)

Key	Type	Default	Description
ValidNV	<i>boolean</i>	true	Indicates whether nonvolatile memory is currently used to store persistent parameters. This is a read-only parameter.
WaitTimeout	<i>integer</i>	40	Indicates the value in seconds to which the user parameter <code>WaitTimeout</code> is initialized at the beginning of each job. This parameter may be set to 0 or any number larger than 0. A value of 0 indicates an infinite wait period.

Device Parameters

Each PostScript interpreter supports a collection of input/output storage devices such as communication channels, disks, and cartridges. You may set device parameters using the `setdevparams` operator, and you may read them using `currentdevparams`. Like system parameters, device parameters require a password, are global to the PostScript environment, have similar persistence characteristics, and some of them can be stored in nonvolatile storage.

Device parameters are different from both system and user parameters in that device parameters may be interdependent. This means that the legality of a given parameter may depend on the value of another parameter.

Device parameters fall into sets that correspond to a particular communications device (`%EtherTalk%`, `%parallel%`, and so on). Some device parameters correspond to a software entity such as a language emulator.

Note

Even if two printers are using the same I/O storage device, the parameters in the set may be different because the hardware support for that device is different. ♦

Device Parameters for Type /FileSystem Devices

The LaserWriter 16/600 PS printer supports `%disk0%` and `%rom%` file system devices. Table 2-11 lists the parameters for `%disk0%` devices.

Table 2-11 Parameters for %disk0% devices

Key	Type	Default	Description
BlockSize	<i>integer</i>	1024	This read-only parameter indicates the formatting size of a page.
Bus	<i>name</i>	(%Scsi%)	Indicates the name of the SCSI bus on which the disk device resides.
Free	<i>integer</i>	Disk dependent	Indicates the amount of free space (in pages) on the media. This parameter is valid only if the media is mounted. A value of zero indicates that the media is not mounted or is completely full.
HasNames	<i>boolean</i>	true	Indicates whether the device supports named files. If the disk is not mounted, this parameter has a value of false.
InitializeAction	<i>integer</i>	0	Specifies an action for initializing the device.
Interleave	<i>integer</i>	5	Specifies the interleave value to use when formatting the device.
LogicalSize	<i>integer</i>	Disk dependent	Specifies the size of the file system to be created and is used as an argument to the action performed by the InitializeAction parameter.
Mounted	<i>boolean</i>	true	Specifies or determines whether a device is mounted or not. When this parameter is set to true, the system attempts to mount the device. When the parameter is set to false the system attempts to dismount the device. When queried, the value indicates whether the device is currently mounted. A value of true indicates the device is mounted and a value of false indicates it is not mounted.
PhysicalSize	<i>integer</i>	Disk dependent	Indicates the size of the media. The value of this parameter is in <i>pages</i> if page size is indicated by the BlockSize parameter. The value is only valid when the device is mounted. A value of zero indicates the device is not mounted.
Removable	<i>boolean</i>	Drive dependent	Indicates whether the device supports removable media. A value of true for this parameter indicates that the device is a removable device.
Searchable	<i>boolean</i>	true	Indicates whether the device supports file system search operations without specifying a device.

continued

Table 2-11 Parameters for %disk0% devices (continued)

Key	Type	Default	Description
SearchOrder	<i>integer</i>	Disk dependent	Indicates the priority at which a device searches for a file when no device has been specified. Lower values indicate a higher priority.
Type	<i>name</i>	/FileSystem	This value is always /FileSystem for %disk0% devices.
Writeable	<i>boolean</i>	Disk dependent	Indicates whether the files on the device can be opened for write access. This parameter can be set to <code>true</code> or <code>false</code> only during the device mounting operation.

The parameters for %rom% file system devices are listed in Table 2-12.

Table 2-12 Parameters for %rom% devices

Key	Type	Default	Description
BlockSize	<i>integer</i>	1	This read-only parameter indicates the formatting size of a page.
CartridgeID	<i>integer</i>	9110	Indicates the ID that uniquely identifies this cartridge.
CartridgeType	<i>integer</i>	4	Indicates the category classification of the cartridge device.
Free	<i>integer</i>	0	Indicates the amount of free space (in pages) on the media. This parameter is set to 0 for cartridge devices.
HasNames	<i>boolean</i>	<code>true</code>	Indicates whether the device supports named files. If the disk is not mounted, this parameter has a value of <code>false</code> .
InitializeAction	<i>integer</i>	0	Specifies an action for initializing the device.
LogicalSize	<i>integer</i>	ROM dependent	Specifies the size of the file system to be created and is used as an argument to the action performed by the <code>InitializeAction</code> parameter.
Mounted	<i>boolean</i>	<code>true</code>	Specifies or determines whether a device is mounted or not. When set to <code>true</code> , the system attempts to mount the device. When set to <code>false</code> , the system attempts to dismount the device. When queried, the value indicates whether the device is currently mounted. A value of <code>true</code> , indicates the device is mounted and a value of <code>false</code> indicates it is not mounted.

continued

Table 2-12 Parameters for %rom% devices (continued)

Key	Type	Default	Description
PhysicalSize	<i>integer</i>	ROM dependent	Indicates the size of the media. This value is in <i>pages</i> if page size is indicated by the <code>BlockSize</code> parameter. The value is only valid when the device is mounted. A value of zero indicates the device is not mounted.
Removable	<i>boolean</i>	false	Indicates whether the device supports removable media.
Searchable	<i>boolean</i>	true	Indicates whether the device supports file system search operations without specifying a device.
SearchOrder	<i>integer</i>	11	Indicates the priority at which a device searches for a file when no device has been specified. Lower values indicate a higher priority.
Type	<i>name</i>	/FileSystem	This value is always /FileSystem for %disk0% devices.
Writeable	<i>boolean</i>	false	Indicates whether the files on the device can be opened for write access. This parameter can be set to <code>true</code> or <code>false</code> only during the device mounting operation.

Communication Device Parameters

The LaserWriter 16/600 PS printer has four communication ports that implement seven communication channels:

- an 9-pin mini-DIN connector is configured to use LocalTalk protocol and supports the %LocalTalk% channel
- a Centronics 36-pin parallel port supports the %Parallel% channel
- a 14-pin AUI connector supports the %EtherTalk%, %LPR%, %NetWorkInterface%, %PrintServer%, and %RemoteServer% channels

Each channel has three related parameter sets:

- nonvolatile
- pending
- RAM

The factory default values for the RAM and pending parameter sets are listed in the tables in this section. The default values for the nonvolatile parameters are the same except that the /Interpreter parameter is always /PostScript.

LocalTalk Parameters

The RS-422 port supports LocalTalk. Table 2-13 lists the factory default settings for %LocalTalk% and %LocalTalk_Pending%.

Table 2-13 Parameters for %LocalTalk% and %LocalTalk_Pending%

Key	Type	Default	Description
DelayedOutputClose	<i>boolean</i>	false	Determines how the output channel is managed after a job completes execution. When the value of this parameter is set to <code>true</code> , an end of file indicator is not sent until all of the pages of a job have been printed. The network channel remains open. Messages such as printer error messages are sent to the channel if it is either the output channel for the job executing, or the output channel for jobs that have finished executing but have not finished printing.
Enabled	<i>boolean</i>	true	Indicates whether data arriving at the printer should be scheduled for processing. If the value of this parameter is <code>true</code> , data is processed. If the value is <code>false</code> , data is not processed.
Filtering	<i>name</i>	/None	Controls whether or not the Adobe IntelliSelect heuristics are used for automatic protocol detection. Supported values are <code>/None</code> , which means that automatic protocol handling does not occur, and <code>/InterpreterBased</code> , which means that the heuristics are used. They are generally used when <code>Interpreter</code> is set to <code>/AutoSelect</code> .
HasNames	<i>boolean</i>	false	Indicates whether the printer supports named files. If the printer is not mounted, or if <code>Type</code> is <code>/Communications</code> , the value of this parameter is <code>false</code> . This value is a read-only constant.

continued

Table 2-13 Parameters for %LocalTalk% and %LocalTalk_Pending% (continued)

Key	Type	Default	Description
Interpreter	<i>name</i>	/PostScript	Indicates the type of executable job represented by the arriving data. Alternatives available on the LaserWriter 16/600 PS are: <ul style="list-style-type: none"> ■ PostScript ■ LaserJetIII ■ AutoSelect
LocalTalkType	<i>string</i>	(LaserWriter)	Represents the Type piece of the LocalTalk entity name. This parameter is set to the name of the printer type. In the case of the LaserWriter 16/600 PS printer, the type is LaserWriter.
NodeID	<i>integer</i>	0	Represents the local network address of the printer. Legal addresses are values between 128 and 254. A value of 0 indicates that the address has not yet been set. This parameter is a read-only constant.
On	<i>boolean</i>	true	Indicates whether or not the printer driver for the communications device is turned on and able to receive and send data. If the value of this parameter is <i>false</i> , data sent to the printer is lost.
Type	<i>name</i>	/Communications	Indicates the general category of device represented by the parameter set.

NOTE 1 All values, with the exception of `Type`, persist across cycles and restarts.

NOTE 2 The `HasNames` and `Type` parameters are read-only constants.

IMPORTANT

Automatic protocol detection may be used with a fixed parameter value to provide Adobe Standard, TBCP, and PJI protocol support. To implement this function, you must set the `Filtering` parameter to `/InterpreterBased`, and the `Interpreter` parameter to `/AutoSelect`.

The `/InterpreterBased` filter does not support asynchronous status inquiries. Therefore it can make many host printer drivers and spoolers unusable. ▲

Parallel Port Parameters

The 36-pin Centronics parallel connector supports parallel communication.

Table 2-14 lists the factory default settings for %Parallel% and %Parallel_Pending%.

Table 2-14 Parameters for %Parallel% and %Parallel_Pending%

Key	Type	Default	Description
DelayedOutputClose	<i>boolean</i>	false	<p>Determines how the output channel is managed after a job completes execution.</p> <p>When the value of this parameter is set to <code>true</code>, an end of file indicator is not sent until all of the pages of a job have been printed. The network channel remains open. Messages such as printer error messages are sent to the channel if it is either the output channel for the job executing, or the output channel for jobs that have finished executing but have not finished printing.</p>
Enabled	<i>boolean</i>	true	<p>Indicates whether data arriving at the printer should be scheduled for processing. If the value of this parameter is <code>true</code>, data is processed. If the value is <code>false</code>, data is not processed.</p>
HandShake	<i>integer</i>	1	<p>Indicates requirements for special handshaking on the parallel port. A value of 0 indicates unidirectional parallel. A value of 1 indicates that the handshaking should occur in accordance with the <i>Hewlett-Packard Parallel Port Interface Specification, Revision 0.6</i>.</p> <p>When this parameter is set to 0, <code>OutputDevice</code> must be set to (). Otherwise, a configuration error will occur.</p>
HasNames	<i>boolean</i>	false	<p>Indicates whether the printer supports named files. If the printer is not mounted, or if <code>Type</code> is <code>/Communications</code>, this value is <code>false</code>. This value is a read-only constant.</p>

continued

Table 2-14 Parameters for %Parallel% and %Parallel_Pending% (continued)

Key	Type	Default	Description
Interpreter	<i>name</i>	/PostScript	Indicates the type of executable job represented by the arriving data. Alternatives available on the LaserWriter 16/600 PS are: <ul style="list-style-type: none"> ■ PostScript ■ LaserJetIII ■ AutoSelect
On	<i>boolean</i>	true	Indicates whether or not the printer driver for the communications device is turned on and able to receive and send data. If the value of this parameter is <i>false</i> , data sent to the printer is lost.
OutputDevice	<i>string</i>	(%Parallel%)	Specifies which communications device to use for <code>stdout</code> and <code>stderr</code> . When this parameter is set to %Parallel% the output is directed back out the parallel port.
Protocol	<i>name</i>	/Raw	Indicates the type of communications protocol to use: <ul style="list-style-type: none"> ■ Binary ■ Normal ■ Raw ■ TBCP (tagged binary communication protocol) For further information on protocols, refer to Section 3.5.3 of the <i>PostScript Language Reference Manual Supplement</i> .
Type	<i>name</i>	/Communications	Indicates the general category of device represented by the parameter set.

NOTE All values, with the exception of Type, persist across cycles and restarts.

EtherTalk Parameters

The 14-pin AUI connector supports EtherTalk communication. Table 2-15 lists the factory default settings for %EtherTalk% and %EtherTalk_Pending%.

Table 2-15 Parameters for %EtherTalk% and %EtherTalk_Pending%

Key	Type	Default	Description
DelayedOutputClose	<i>boolean</i>	false	Determines how the output channel is managed after a job completes execution. When the value of this parameter is set to <i>true</i> , an end of file indicator is not sent until all pages of a job have been printed. The network channel remains open. Messages such as printer error messages are sent to the channel if it is either the output channel for the job executing, or the output channel for jobs that have finished executing but have not finished printing.
Enabled	<i>boolean</i>	true	Indicates whether data arriving at the printer should be scheduled for processing. If the value of this parameter is <i>true</i> , data is processed. If the value is <i>false</i> , data is not processed.
EthernetAddress	<i>string</i>	Hardware dependent	A unique 17-character string that represents the Ethernet address of the printer.
EtherTalkType	<i>string</i>	(LaserWriter)	Indicates the <i>type</i> piece of the EtherTalk <i>entity name</i> . The entity name consists of three pieces: <i>zone</i> , <i>type</i> , and <i>object</i> , each of which is a string of 32 or fewer non-null characters. Setting the EtherTalkType string will also set the LocalTalkType parameter within the %LocalTalk% parameter set to the same value. The appletalktype compatability operator will also reflect the same value.
EtherTalkZone	<i>string</i>	(*)	Indicates the zone piece of the EtherTalk entity name.
Filtering	<i>name</i>	/None	Indicates whether the input data stream needs further filtering before it can be correctly interpreted as a page description language.

continued

Table 2-15 Parameters for %EtherTalk% and %EtherTalk_Pending% (continued)

Key	Type	Default	Description
HasNames	<i>boolean</i>	false	Indicates whether the printer supports named files. If the printer is not mounted, or if Type is /Communications, the value of this parameter is false. This value is a read-only constant.
Interpreter	<i>name</i>	/PostScript	Indicates the type of executable job represented by the arriving data. Alternatives available on the LaserWriter 16/600 PS are: <ul style="list-style-type: none"> ■ PostScript ■ LaserJetIII ■ AutoSelect
On	<i>boolean</i>	true	Indicates whether or not the printer driver for the communications device is turned on and able to receive and send data. If the value of this parameter is false, data sent to the printer is lost.
Type	<i>name</i>	/Communications	Indicates the general category of device represented by the parameter set.

Network Interface Parameters

The 14-pin AUI connector supports Ethernet network communication. Table 2-16 lists the factory default settings for %NetworkInterface% and %NetworkInterface_Pending%.

Table 2-16 Parameters for %NetworkInterface% and %NetworkInterface_Pending%

Key	Type	Default	Description
DelayedOutputClose	<i>boolean</i>	false	Determines how the output channel is managed after a job completes execution. <p>When the value of this parameter is set to true, an end of file indicator is not sent until all of the pages of a job have been printed. The network channel remains open. Messages such as printer error messages are sent to the channel if it is either the output channel for the job executing, or the output channel for jobs that have finished executing but have not finished printing.</p>

continued

Table 2-16 Parameters for %NetworkInterface% and %NetworkInterface_Pending% (continued)

Key	Type	Default	Description
Enabled	<i>boolean</i>	true	Indicates whether data arriving at the printer should be scheduled for execution. If the value of this parameter is <code>true</code> , data is executed. If the value is <code>false</code> , data is not executed. Always set the value of this parameter to <code>true</code> for this communications channel.
EthernetAddress	<i>string</i>	Hardware dependent	A unique 17-character string that represents the Ethernet address of the printer.
EthernetType	<i>name</i>	/AUI	
Filtering	<i>name</i>	/None	Indicates whether the input data stream needs further filtering before it can be correctly interpreted as a page description language.
FrameType	<i>name</i>	802.3	Indicates the frame type being used on the Ethernet port.
HasNames	<i>boolean</i>	false	Indicates whether the printer supports named files. If the printer is not mounted, or if <code>Type</code> is <code>/Communications</code> , the value of this parameter is <code>false</code> . This value is a read-only constant.
IPAddress	<i>string</i>	(0.0.0.0)	Controls the IP address used for IP connections. The default value of (0.0.0.0) indicates the reverse address resolution protocol. If the value is set to any other number, that number is used as the IP address of the printer.
Interpreter	<i>name</i>	/PostScript	Indicates the type of executable job represented by the arriving data. Alternatives available on the LaserWriter 16/600 PS are: <ul style="list-style-type: none"> ■ PostScript ■ LaserJetIII ■ AutoSelect
NetworkName	<i>string</i>	(LaserWriter 16/600 PS)	Indicates the name actually chosen by the printer on the network. Due to name conflicts, this name may not be the same as the value for the system parameter <code>PrinterName</code> .

continued

Table 2-16 Parameters for %NetworkInterface% and %NetworkInterface_Pending% (continued)

Key	Type	Default	Description
On	<i>boolean</i>	true	Indicates whether or not the printer driver for the communications device is turned on and able to receive and send data. If the value of this parameter is <i>false</i> , data sent to the printer is lost. Always set the value of this parameter to <i>true</i> for this channel.
ROMVersion	<i>string</i>	1.0	Indicates the network firmware version of the current printer.
Type	<i>name</i>	/Communications	Indicates the general category of device represented by the parameter set.

Network Printer Parameters

The 14-pin AUI connector supports Ethernet network communication. The LaserWriter 16/600 PS printer can act as a line printer device (%LPR%), a Novell remote printer device (%RemotePrinter%), and a print server device (%PrintServer%) on the Ethernet network channel. The parameters for %LPR%, %LPR_Pending%, %RemotePrinter%, %RemotePrinter_Pending%, %PrintServer%, and %PrintServer_Pending% are listed in Table 2-17.

Table 2-17 Parameters for network printers

Key	Type	Default	Description
DelayedOutputClose	<i>boolean</i>	false	Determines how the output channel is managed after a job completes execution. When the value of this parameter is set to <i>true</i> , an end of file indicator is not sent until all of the pages of a job have been printed. The network channel remains open. Messages such as printer error messages are sent to the channel if it is either the output channel for the job executing, or the output channel for jobs that have finished executing but have not finished printing.

continued

Table 2-17 Parameters for network printers (continued)

Key	Type	Default	Description
Enabled	<i>boolean</i>	true	Indicates whether data arriving at the printer should be scheduled for execution. If the value of this parameter is <code>true</code> , data is executed. If the value is <code>false</code> , data is not executed. Always set this parameter to <code>true</code> for this channel.
Filtering	<i>name</i>	/None	Indicates whether the input data stream needs further filtering before it can be correctly interpreted as a page description language.
HasNames	<i>boolean</i>	false	Indicates whether the printer supports named files. If the printer is not mounted, or if <code>Type</code> is <code>/Communications</code> , the value of this parameter is <code>false</code> . This value is a read-only constant.
Interpreter	<i>name</i>	/AutoSelect	Indicates the type of executable job represented by the arriving data. Alternatives available on the LaserWriter 16/600 PS are: <ul style="list-style-type: none"> ■ PostScript ■ LaserJetIII ■ AutoSelect
On	<i>boolean</i>	true	Indicates whether or not the printer driver for the communications device is turned on and able to receive and send data. If the value of this parameter is <code>false</code> , data sent to the printer is lost. Always set this parameter to <code>true</code> for this channel.
Type	<i>name</i>	/Communications	Indicates the general category of device represented by the parameter set.

SCSI Bus Parameters

The parameters for configuring the SCSI bus are included in the `%Scsi%` bus devices parameter set. The parameters for `%Scsi%` bus devices are listed in Table 2-18.

Table 2-18 Parameters for %Scsi% bus devices

Key	Type	Default	Description
BootDelay	<i>integer</i>	0	Indicates how long the disk I/O driver should wait for the disk to spin up before determining that the disk in the printer is not present or responding. A value of 0 indicates no waiting.
CheckParity	<i>boolean</i>	false	Indicates whether or not to check parity on the SCSI bus.
InitiatorID	<i>integer</i>	7	Indicates the address on the SCSI bus used by the printer when it serves as the initiator.
Poll	<i>integer</i>	127	A bit encoded specification of the addresses on the SCSI bus that should be polled by the printer when looking for disks during PostScript system initialization.
TargetID	<i>integer</i>	7	Indicates the SCSI bus address reserved for use as the %ScsiComm% communications channel. May be the same value as the InitiatorID.
Type	<i>name</i>	/Parameters	This constant always returns a value of /Parameters.

Engine Device Parameters

The %Engine% device contains parameters that control the print engine itself. The LaserWriter 16/600 PS printer's %Engine% device contains the parameters listed in Table 2-19.

Table 2-19 Parameters for %Engine% devices

Key	Type	Default	Description
Darkness	<i>real</i>	0.5	Controls the amount of toner applied to the paper. A value of 0.0 signifies the minimum darkness, and 1.0 signifies the maximum darkness. Values outside this range are not legal. The LaserWriter 16/600 PS printer supports 16 levels of darkness, so this parameter is quantized into 16 steps. This is done by taking the integer portion of $\text{Darkness} * 15$. Therefore, a value of 0.0 is not distinguishable from 0.05, but it is distinguishable from 0.1. Changes in the Darkness parameter are not sent to the engine until there are no pages in the paper path, either feeding or being copied. This value persists across power cycles and restarts.

continued

Table 2-19 Parameters for %Engine% devices (continued)

Key	Type	Default	Description
PageCount	<i>integer</i>	0	Keeps count of all pages fed by the printer engine. The count includes all pages successfully printed as well as pages that were jammed or spoiled. You can get the value by querying the engine.
TimeToStandby	<i>integer</i>	60	If the printer is not actually in use, the engine goes into standby mode after the number of minutes specified by this parameter. This means the engine does not keep the fuser hot, and the next time the controller sends a feed or prefeed command, the engine starts to warm up. This value persists across power cycles and restarts.
Type	<i>name</i>	/Parameters	This constant always returns a value of /Parameters. This value is a read-only constant.

Fax Device Parameters

The %Fax% device is used to control the default fax operating parameters of the LaserWriter 16/600 PS printer. The %Fax% device parameters are described in Table 2-20.

Table 2-20 Parameters for the %Fax% device

Key	Type	Default	Description
ActivityReport	<i>boolean</i>	false	Determines how the fax activity report is handled. A value of <code>true</code> indicates that a report is printed automatically whenever the activity buffer is full. A value of <code>false</code> , indicates that a report is not printed automatically. Printing a report does not clear the recorded information; the oldest entries are overwritten with new entries. Reports may be generated by request from the host.
DefaultCaptionOn	<i>boolean</i>	true	Determines whether a default page caption appears on the printed fax pages.
DefaultConfirmOn	<i>boolean</i>	true	Determines whether a confirmation report is generated by the default procedures.

continued

Table 2-20 Parameters for the %Fax% device (continued)

Key	Type	Default	Description
DefaultCoversOn	<i>boolean</i>	true	Determines whether cover pages are generated by the default cover page procedure.
DefaultResolution	<i>integer</i>	1	If the value of FaxType in the FaxOptions dictionary is null, then the value of this parameter determines the resolution of the fax. A value of 1 specifies CCITT group 3 resolution.
DefaultRetryCount	<i>integer</i>	0	Determines the number of times to retry generating a fax if the value of MaxRetries in the FaxOptions dictionary is null.
DefaultRetryInterval	<i>integer</i>	3	Determines the amount of time between retries if the value of RetryInterval in the FaxOptions dictionary is null. The value represents minutes between retries.
DialToneWaitPeriod	<i>integer</i>	1	Indicates the maximum number of seconds to wait for a dial tone when dialing. The value of this parameter is used whenever the fax printer begins dialing and when it encounters the letter "w" in the dialing string. If a dialtone is not detected in this time frame, the wait is considered to have failed.
Group3Adjustment	<i>integer</i>	2	Determines how received faxes are processed for printing. The value 0 indicates fine print mode with a sample rate of 2 to 3. A value of 1 treats the fax as if it were 300 by 300 dots per inch. Pages are printed at approximately two thirds the original size. A value of 2 scales the fax for best fit on the selected page size. Halftones may be produced inaccurately when this method is selected. Values of 10001 or greater invoke user-programmable procedures.
ID	<i>string</i>	()	Indicates the string by which the fax printer identifies itself to other fax machines. This string can contain up to 20 characters.

continued

Table 2-20 Parameters for the %Fax% device (continued)

Key	Type	Default	Description
LocalLanguage	<i>string</i>	(English)	Provides the natural language to use when printing transmission reports and activity logs on LaserWriter 16/600 PS printers. The default value is (English). Other values supported include: (Dutch), (French), (German), (Italian), and (Spanish). Translation dictionaries for other printers may also be uploaded to the printer. If a dictionary for a specified language is not available, the English dictionary is used. This value can be up to 50 characters in length.
MaxFaxBuffer	<i>integer</i>	RAM dependent	Determines the upper limit of the number of bytes of printer RAM that can be used for incoming and outgoing fax data. This value is used only when the StorageDevice parameter has a value of (%ram%). Memory used is based on the total amount of RAM in the printer, as follows: <ul style="list-style-type: none"> >16 MB = 8 MB fax buffer >10 MB = 4 MB fax buffer >8 MB = 2 MB fax buffer The memory is not allocated and locked for the data buffer. The value of this parameter is only an upper limit.
PostScriptPassword	<i>string</i>	()	Provides a method for setting a password, which is then required to use the fax capabilities of the printer. This applies to sending as well as receiving faxes. The default value is no password. Maximum length of the password is 32 characters.
ProtocolVersion	<i>string</i>	(2.108)	Indicates the version of the T.30 fax code in the printer.
ReceivePostScript	<i>boolean</i>	true	Determines whether the fax printer receives PostScript language files. A value of true indicates that the printer does receive PostScript files. A value of false indicates that PostScript files are not accepted and only CCITT compressed raster format faxes are accepted.

continued

Table 2-20 Parameters for the %Fax% device (continued)

Key	Type	Default	Description
Rings	<i>integer</i>	2	Determines how many rings are ignored before the fax printer answers the phone. This number can be any positive value in the range of 1 to 10.
ServiceEnable	<i>integer</i>	3	Determines the master on-off control for the fax printer send and receive features. Integer values are: 0 = Fax completely disabled 1 = Send only 2 = Receive only 3 = Send and receive
Speaker	<i>integer</i>	1	Determines how the speaker operates during fax operation. Integer values are: 0 = Off at all times 1 = On until connection is established 2 = On at all times
StorageDevice	<i>string</i>	(%ram%)	Determines the name of the device that holds received fax data before it is printed, and holds outgoing fax data before it is sent. The default value of (%ram%) indicates printer RAM is used for storage. If another device such as a disk is specified, that device must be mounted. Changes to this parameter take effect after the printer is reinitialized.
Type	<i>name</i>	/Parameters	This constant always returns a value of /Parameters.
WaitForDialTone	<i>boolean</i>	true	Determines whether the fax printer needs to detect a dialtone before it starts to dial. When the value of this parameter is <code>true</code> , the fax printer waits for a dialtone the maximum time indicated by the value of the <code>DialToneWaitPeriod</code> parameter. When the value is <code>false</code> , the call is dialed whether a dialtone is detected or not.

Emulator Parameters

The LaserWriter 16/600 PS printer can emulate the Hewlett-Packard LaserJet III. To do this, it requires an alternative interpreter for the input stream. The interpreter requires a set of emulator parameters to implement the emulation. The %LaserJetIII% emulator

(PCL5) is a body of code that processes data and generates pages of output. The language that is processed is specified by Hewlett-Packard. Adobe Systems has emulated the actions of the Hewlett-Packard printer series as closely as possible.

Typically, PCL5 consumes data from the host, produces pages, and then terminates its operation. In some cases, you will want to set the environment for PCL5 before the print job begins. Table 2-21 lists and defines the parameters you use to change attributes such as default font.

IMPORTANT

Certain parameters, as noted in Table 2-21, were originally used to select the default font and are now obsolete. They are listed in this table for your information only. You should not use these parameters. ▲

Table 2-21 Parameters for the %LaserJetIII% emulator

Key	Type	Default	Description
Copies	<i>integer</i>	1	Specifies the default number of copies to be printed.
Duplex	<i>integer</i>	0	Sets the initial state of duplexing within a PCL job for printers capable of duplex operation. Language commands within the print stream can override the setting of this parameter. The values 0, 1, and 2 are acceptable: 0 Simplex 1 Long-edge binding duplex 2 Short-edge binding duplex
FontFixed	<i>boolean</i>	true	Selects the font pitch. If the value of this parameter is <code>true</code> , a fixed font such as <code>Courier</code> , is selected. If the value is <code>false</code> , a proportionally spaced font, such as <code>Helvetica®</code> , is selected. This is an obsolete parameter, originally used to select the default font. It is used only if the <code>FontSource</code> parameter is set to -1.

continued

Table 2-21 Parameters for the %LaserJetIII% emulator (continued)

Key	Type	Default	Description
FontHeight	<i>integer</i>	1200	<p>Selects the height of the font and is applicable to scalable proportional fonts. The value set is the point size, multiplied by 100 to avoid floating point representation. For instance, the default value 1200 specifies a 12-point font.</p> <p>Note that this value is used only if the font specified by the combination FontSource and FontNumber is scalable and proportional.</p>
FontItalic	<i>boolean</i>	false	<p>If this parameter is true, an <i>italic</i> or <i>oblique</i> font is requested.</p> <p>This is an obsolete parameter, originally used to select the default font. This parameter is used only if the FontSource parameter is set to -1.</p>
FontNumber	<i>integer</i>	-1	<p>Selects the font within the current FontSource. Applicable values are determined based upon FontSource and the number of fonts that are available from that font source. If the FontNumber parameter specified is outside the range, the value 0 is used instead.</p>
FontPitch	<i>real</i>	1000	<p>Specifies the number of characters per inch to be used for monospace scalable fonts. The value is multiplied by 100 to avoid floating-point representation. To select a 12-pitch font, you use the value 1200. This parameter is used only by the PCL5 interpreter if the font specified by the combination FontSource and FontNumber is scalable and monospace.</p>

continued

Table 2-21 Parameters for the %LaserJetIII% emulator (continued)

Key	Type	Default	Description
FontSource	<i>integer</i>	0	<p>Selects the source of the desired font. Currently, 0 selects an internal font, and 1 selects a downloaded font.</p> <p>The value -1 is used when there is to be no selection of a default font. In this case, the obsolete method of selection, described later in this section, is used to select the font source. This method uses the parameters FontFixed, FontItalic, FontWeight, and FontTypeFace.</p>
FontSymbolSet	<i>integer</i>	277	<p>This parameter is the equivalent of the Symbol Set code. The applicable values are described in Hewlett-Packard manuals. Note that this value is consulted only if the font specified by the combination FontSource and FontNumber is an unbound font. There are 35 legal values. See Table 2-22 for further information on Symbol Set legal values.</p>
FontTypeface	<i>integer</i>	3	<p>Describes the typeface, for example, Times[®], Helvetica, Palatino[®], and so on. The integer value, which can be up to 16 bits, comes from a table published by Hewlett-Packard.</p> <p>This is an obsolete parameter, originally used to select the default font. It is used only if the FontSource parameter is set to -1.</p>
FontWeight	<i>integer</i>	0	<p>Specifies the weight or boldness of the font. For example, -7 is very light and +7 is very bold.</p> <p>This is an obsolete parameter, originally used to select the default font. It is used only if the FontSource parameter is set to -1.</p>

continued

Table 2-21 Parameters for the %LaserJetIII% emulator (continued)

Key	Type	Default	Description
Landscape	<i>boolean</i>	false	Determines whether the initial orientation of the page will be landscape or portrait. If the value of this parameter is <code>true</code> , the page orientation will be landscape. If the value is <code>false</code> , the page orientation will be portrait.
Linewrap	<i>boolean</i>	false	Decides whether long lines are wrapped to the next line or truncated. If the value of this parameter is <code>true</code> , long lines wrap to the next line. If the value is <code>false</code> , long lines are truncated.
MaxLJMemory	<i>integer</i>	RAM dependent	Specifies the maximum amount of memory the emulator will ask for from the page allocator to store downloaded fonts and macros. The default value is 700K bytes for 4 MB of RAM and 500K bytes for each additional 1 MB of RAM installed. The limit is important because the emulator acquires memory at the expense of the PostScript interpreter's memory needs for items such as virtual memory or font cache. The <code>MaxLJMemory</code> parameter is rounded to the nearest multiple of a memory block size (8192 bytes).
PaperSize	<i>integer</i>	-1	Sets the size of paper to be used within the PCL job. Values available are: -1 Unspecified 1 Executive 2 Letter 3 Legal 26 A4 80 Monarch envelope 81 Com-10 envelope 90 International dl envelope 91 International C5 envelope
TopMargin	<i>integer</i>	3600	Specifies in IPU (1/7200 inch) the amount of white space at the top of the page. The default, 3600, represents half an inch.

continued

Table 2-21 Parameters for the %LaserJetIII% emulator (continued)

Key	Type	Default	Description
Type	<i>name</i>	/Emulator	Indicates the general category of device represented by the parameter set. For the LaserWriter 16/600 PS printer, /Emulator is the only available value.
VMI	<i>real</i>	1200	Specifies the space between lines of text in 1/7200 inch units. The default, 1200, represents 1/6 inch.
WaitTimeout	<i>integer</i>	30	Specifies the time in seconds after which a page is ejected.

NOTE All values, with the exception of Type, persist across power cycles and restarts.

The Symbol Set code has 35 legal values, as listed in Table 2-22.

Table 2-22 Symbol Set code legal values

Value	Symbol Set code
4	*/OD "ISO-60 Norweg"*/
6	*/OF "ISO-25 French"*/
7	*/OG "German"*/
9	*/OI "ISO-15 Italian"*/
11	*/OK "ISO-14 JISASCII"*/
14	*/ON "ECMA-94 Latin 1"*/
19	*/OS "ISO-11 Swedish"*/
21	*/OU "ISO-6 ASCII"*/
36	*/1D "ISO-61 Norweg"*/
37	*/1E "ISO-4 UK"*/
38	*/1F "ISO-69 French"*/
39	*/1G "ISO-21 German"*/
51	*/1S "Spanish"*/
53	*/1U "Legal"*/
75	*/2K "ISO-57 Chinese"*/
83	*/2S "ISO-17 Spanish"*/
85	*/2U "ISO-2 IRV"*/
115	*/3S "ISO-10 Swedish"*/

continued

Table 2-22 Symbol Set code legal values (continued)

Value	Symbol Set code
147	<code>*/4S "ISO-16 Portug"*/</code>
173	<code>*/5M "PS-Math"*/</code>
179	<code>*/5S "ISO-84 Portug"*/</code>
202	<code>*/6J "Microsoft Pub"*/</code>
205	<code>*/6M "Ventura Math"*/</code>
211	<code>*/6S "ISO-85 Spanish"*/</code>
234	<code>*/7J "Desktop"*/</code>
269	<code>*/8M "Math-8"*/</code>
277	<code>*/8U "Roman-8"*/</code>
309	<code>*/9U "Windows"*/</code>
330	<code>*/10J "PS-Text"*/</code>
341	<code>*/10U "PC-8 US"*/</code>
373	<code>*/11U "PC-8 DN"*/</code>
405	<code>*/12U "PC-850"*/</code>
426	<code>*/13J "Ventura Intl"*/</code>
458	<code>*/14J "Ventura US"*/</code>
501	<code>*/15U "PiFont"*/</code>

Resource Categories

In PostScript Language Level 2, PostScript objects such as fonts, patterns, and filters can be managed as open-ended collections of resources grouped into categories. A resource is requested by resource category and name. If the resource does not reside in virtual memory, the resource management mechanism loads it from an external source, such as a disk, a ROM cartridge, or a network file server. The *PostScript Language Reference Manual*, second edition discusses named resources in detail.

There are several groups of resources:

- New resources in the regular resource categories can be added. These include such items as font and pattern resources (Table 2-23).
- Categories of implicit resources represent built-in capabilities of the LaserWriter 16/600 PS interpreter. For example, the `FontType` category indicates that the interpreter understands Type 1 only (Table 2-27).
- Some resources are used to define new categories (Table 2-28).

LaserWriter 16/600 PS Software

Most of the instances listed in the following tables are described in the *PostScript Language Reference Manual*, second edition, or the *PostScript Language Reference Manual Supplement*.

Regular Resource Categories

Table 2-23 lists the new resources in regular resource categories.

Table 2-23 Regular resource categories

Category name	Instances
Encoding	ISOLatin1Encoding StandardEncoding
Font	AvantGarde-Book AvantGarde-BookOblique AvantGarde-Demi AvantGarde-DemiOblique Bookman-Demi Bookman-DemiItalic Bookman-Light Bookman-LightItalic Courier Courier-Bold Courier-BoldOblique Courier-Oblique Helvetica Helvetica-Bold Helvetica-BoldOblique Helvetica-Narrow Helvetica-Narrow-Bold Helvetica-Narrow-BoldOblique Helvetica-Narrow-Oblique Helvetica-Oblique NewCenturySchlbk-Bold NewCenturySchlbk-BoldItalic NewCenturySchlbk-Italic NewCenturySchlbk-Roman Palatino-Bold Palatino-BoldItalic Palatino-Italic Palatino-Roman Symbol Times-Bold Times-BoldItalic Times-Italic Times-Roman ZapfChancery-Medium Italic ZapfDingbats

continued

Table 2-23 Regular resource categories (continued)

Category name	Instances
Form	No instances defined.
Halftone	DefaultHalftone 141 x 45 141 x 45d 106 x 45 106 x 45d 85 x 45
HWOptions	Clock Fax
Pattern	No instances defined.
ProcSet	DiagnosticProcs FaxAdminOps FaxDefaultProcs FaxOps LaserJetIII SamplePages Test The LaserWriter 16/600 PS printer has eight predefined ProcSet instances. The DiagnosticProcs instance is not documented, and its procedures should not be called.
OutputDevice	Default Fax FaxReceived Printer The OutputDevice resource category has an instance for each device type, Printer, Fax, and FaxReceived, plus an instance called Default for the default output device characteristics. The default output device is equivalent to the Printer instance. Each instance is represented as a resource dictionary containing key-value pairs describing certain capabilities of that particular output device. For details about key-value pairs for Fax output devices, see Table 2-24. For details about key-value pairs for FaxReceived output devices, see Table 2-25. For details about key-value pairs for Printer output devices, see Table 2-26. The OutputDevice resource category performs the following functions: <ul style="list-style-type: none"> ■ Enables applications to query printer capabilities directly. ■ Maintains functional equivalence with PostScript Language Level 1.

Key-Value Pairs for Fax Output Device Resources

Table 2-24 lists the key-value pairs in the resource dictionary for Fax output devices.

Table 2-24 Resource dictionary for Fax output device instances

Key	Value
HWResolution	[200 100] [200 200]
PageSize	[612 792] [612 1008]
ProcessColorModel	DeviceGray

Key-Value Pairs for FaxReceived Output Device Resources

Table 2-25 lists the key-value pairs in the resource dictionary for FaxReceived output devices.

Table 2-25 Resource dictionary for FaxReceived output device instances

Key	Value
HWResolution	[600 600]
PageSize	[612 792] [612 1008] [595 842] [420 595] [516 729] [297 684] [279 540] [460 649] [312 624]
ProcessColorModel	DeviceGray

Key-Value Pairs for Printer Output Device Resources

Table 2-26 lists the key-value pairs in the resource dictionary for Printer output devices.

Table 2-26 Resource dictionary for Printer output device instances

Key	Value
HWResolution	[600 600]
ManualSize	[612 792] [612 1008] [595 842] [420 595] [516 729] [522 756] [297 684] [279 540] [460 649] [312 624]
PageSize	[612 792] [612 1008] [595 842] [420 595] [516 729] [297 684] [279 540] [460 649] [312 624]
ProcessColorModel	DeviceGray

Implicit Resource Categories

Table 2-27 lists categories of implicit resources for the built-in capabilities of the LaserWriter 16/600 PS interpreter.

Table 2-27 Resources with implicit instances

Category name	Instances
ColorRendering	DefaultColorRendering
ColorRenderingType	1
ColorSpace	No instances defined.
ColorSpaceFamily	CIEBasedA CIEBasedABC DeviceCMYK DeviceGray DeviceRGB Indexed Pattern Separation
Emulator	LaserJetIII
Filter	ASCII85Decode ASCIIHexDecode ASCII85Encode ASCIIHexEncode CCITTFaxDecode CCITTFaxEncode DCTDecode DCTEncode LZWDecode LZWEncode NullEncode RunLengthDecode RunLengthEncode SubFileDecode
FMaptype	2, 3, 4, 5, 6, 7, 8
FontType	0, 1, 3, 4, 5, 6, 42
	The integers 0, 1, 3, 4, 5, and 6 are the instances supported for the LaserWriter 16/600 PS printer.
	The value of 42 indicates the printer has a TrueType font rasterizer built-in.
FormType	1
HalftoneType	1, 2, 3, 4, 5, 6

continued

Table 2-27 Resources with implicit instances (continued)

Category name	Instances
IODevice	%Calendar% %disk0% %Engine% %EtherTalk% %EtherTalk_NV% %EtherTalk_Pending% %Fax% %LaserJetIII% %LocalTalk% %LocalTalk_NV% %LocalTalk_Pending% %LPR% %LPR_NV% %LPR_Pending% %NetworkInterface% %NetworkInterface_NV% %NetworkInterface_Pending% %Parallel% %Parallel_NV% %Parallel_Pending% %PrintServer% %PrintServer_NV% %PrintServer_Pending% %RemotePrinter% %RemotePrinter_NV% %RemotePrinter_Pending% %rom% %Scsi%
ImageType	1
PatternType	1

Resource Categories for Defining New Resources

Table 2-28 defines resources used to define new categories.

Table 2-28 Resources to define new categories

Category	Instances
Category	Category ColorRendering ColorRenderingType ColorSpace ColorSpaceFamily Emulator Encoding Filter FMapType Font FontType Form FormType Generic Halftone HalftoneType HWOptions ImageType IODevice OutputDevice Pattern PatternType ProcSet
Generic	No instances defined.

Resources for Accessing Hardware Options

The `HWOptions` resource category provides access to optional features that are installed in the LaserWriter 16/600 PS printer. This resource is the only facility available for determining if hardware options are present in the printer. Instance entries for optional hardware features that are not currently installed in the printer will not appear in the `HWOptions` resource.

Table 2-29 lists the hardware option instances available (when installed) in the `HWOptions` resource category.

Table 2-29 Hardware option instances for the `HWOptions` resource category

Instance	Type	Value
Clock	<i>string</i>	(TODClock)
Fax	<i>string</i>	(USModem)

PostScript Level 1 Compatibility Operators

PostScript Level 1 Compatibility Operators

The PostScript language is designed to be a universal standard for device-independent page descriptions, but each PostScript language implementation supports features and capabilities particular to that implementation. For that reason, the PostScript language has a number of significant extensions. Appendix D, “Compatibility Strategies,” in the *PostScript Language Reference Manual*, second edition, presents guidelines for taking advantage of language extensions while maintaining compatibility with PostScript interpreters.

The LaserWriter 16/600 PS printer is a Level 2 printer. This chapter lists the compatibility operators that make the LaserWriter 16/600 PS printer compatible with existing PostScript Level 1 language driver software. It also defines compatibility operators that are not found, or that differ from the operators described in the Compatibility chapter of the *PostScript Language Reference Manual Supplement* for Version 2014 of the PostScript programming language.

Overview of Compatibility Operators

The compatibility operators present in the LaserWriter 16/600 PS printer appear in three dictionaries: `statusdict`, `userdict`, and `systemdict`. These operators set

- system parameters
- page device parameters
- user parameters
- device parameters

This chapter describes the page size and paper tray compatibility operators.

▲ **WARNING**

The operators described in this chapter are included only to support compatibility with PostScript Level 1 programs. You should not use them in PostScript Level 2 programs. ▲

Table 3-1 provides a complete list of compatibility operators arranged by dictionary.

PostScript Level 1 Compatibility Operators

Table 3-1 Compatibility operators**statusdict**

a4tray	pagecount
a5tray	pagestackorder
appletalktype	papersize
b5tray	printrname
buildtime	product
byteorder	ramsize
c5tray	realformat
checkpassword	revision
com10tray	setdefaultmultipurposetraysize
defaultpapertray	setdefaultpapertray
defaulttimeouts	setdefaulttimeouts
diskonline	setdostartpage
diskstatus	setdosysstart
dltray	setjobtimeout
dostartpage	setmargins
dosysstart	setpagestackorder
emulate	setpapertray
initializedisk	setprintrname
jobname	setsoftwareiomode
jobtimeout	setuserdiskpercent
legaltray	softwareiomode
lettertray	userdiskpercent
manualfeed	waittimeout
margins	
monarchtray	

userdict

#copies	dl
a4	legal
a4small	letter
a5	lettersmall
b5	monarch
c5	note
com10	

systemdict

devdismount	devmount
devforall	devstatus
devformat	

Page Size Compatibility Operators

The page size operators are in the user dictionary `userdict`. Each operator requests a specific paper size and imaging boundary box, as shown in Table 3-2. The operators use the sizes indicated in the table as a page device `PageSize` parameter. All operators set the `Policy` for `PageSize` to 7, which guarantees that the imaging area established is correct for the size requested, regardless of which paper tray is chosen.

The only error generated is `limitcheck`, which occurs when there is not sufficient memory for the imaging area requested.

Table 3-2 Page size compatibility operators

Operator	Page size	Imaging boundary box
<code>a4</code>	[595 842]	null
<code>a4small</code>	[595 842]	[25 25 570 817]
<code>a5</code>	[420 595]	null
<code>b5</code>	[516 729]	null
<code>c5</code>	[459 649]	null
<code>com10</code>	[297 684]	null
<code>d1</code>	[312 624]	null
<code>legal</code>	[612 1008]	null
<code>letter</code>	[612 792]	null
<code>lettersmall</code>	[612 792]	[25 25 587 767]
<code>monarch</code>	[279 540]	null
<code>note</code>	[<i>width height</i>]	[25 25 <i>width-25 height-25</i>]

NOTE Units shown (595, for example) are points. One point is 1/72 inch.

The `note` operator modifies the current page device settings by establishing an `ImagingBBox` parameter of [25 25 *width* minus 25 *height* minus 25] if the current `PageSize` parameter is [*width height*].

Paper Tray Compatibility Operators

The paper tray operators are in the status dictionary `statusdict`. Each operator requests a tray containing a specific paper size. The only difference between the operators is the size of paper requested. The `PageSize` and `ImagingBBox` parameters requested are the same as those for the corresponding page size operator. These operators use the specified size as a page device `PageSize` parameter. All the operators set the `Policy` for `PageSize` to 0, which guarantees that a `rangecheck` error is generated if a tray containing the requested paper size is not found. In addition, a `limitcheck` error can occur if there is not sufficient memory for the imaging area requested.

The paper tray compatibility operators and associated page sizes and imaging boundary box parameters are shown in Table 3-1.

Table 3-3 Paper tray compatibility operators

Operator	Page size	Imaging boundary box
<code>a4tray</code>	[595 842]	null
<code>a5tray</code>	[420 595]	null
<code>b5tray</code>	[516 729] or [499 709]	null
<code>c5tray</code>	[461 648]	null
<code>com10tray</code>	[297 684]	null
<code>dltray</code>	[312 624]	null
<code>legaltray</code>	[612 1008]	null
<code>lettertray</code>	[612 792]	null
<code>monarchtray</code>	[279 540]	null

Compatibility Operator Descriptions

This section describes the compatibility operators that are not found, or that differ from the operators described in the Compatibility chapter of the *PostScript Language Reference Manual Supplement* for Version 2014 of the PostScript programming language.

PostScript Level 1 Compatibility Operators

The compatibility operators described in this section deal with paper size and paper tray sizes. The various tray sizes are represented with a tray slot number. The tray slot numbers and the associated tray descriptions are listed in Table 3-3.

Table 3-4 Tray numbers and descriptions for compatibility operators

Tray slot number	Tray description
0	Main tray
1	Multipurpose tray
2	500 sheet tray
3	Envelope tray

defaultmultipurposetraysize

Syntax	- defaultmultipurposetraysize <i>name bool</i>
Definition	This operator returns the name of the default multipurpose paper tray. The Boolean value <i>bool</i> is true if the paper feeds short edge first. It is false, if it feeds long edge first. The Boolean value is always true, because paper only feeds into the LaserWriter 16/600 PS printer short edge first.
Error(s)	stackoverflow

defaultpapertray

Syntax	- defaultpapertray <i>int</i>
Definition	This operator returns an integer that is the first element in the <i>Priority</i> array of the <i>InputAttributes</i> dictionary found within the current page device. This value represents the default paper tray slot, which may or may not be installed. If there is no <i>Priority</i> array within the <i>InputAttributes</i> array at the time <i>defaultpapertray</i> is called, an arbitrary slot number is returned.
Error(s)	stackoverflow

papersize

Syntax	- <code>papersize name bool</code>
Definition	This operator returns the name of the compatibility operator that selects a tray containing the current media size. For example, if the current selected paper is letter size paper, the <code>/lettertray</code> name is returned. The Boolean value <i>bool</i> is true if the paper feeds short edge first. It is false if the paper feeds long edge first.
Error(s)	<code>stackoverflow</code>

papertray

Syntax	- <code>papertray int</code>
Definition	This operator returns an integer that is the first element in the <code>Priority</code> array of the <code>InputAttributes</code> dictionary found within the current page device. This value represents the default paper tray slot, which may or may not be installed. If there is no <code>Priority</code> array within the <code>InputAttributes</code> array at the time <code>papertray</code> is called, an arbitrary slot number is returned.
Error(s)	<code>stackoverflow</code>

setdefaultmultipurposetraysize

Syntax	<code>name bool setdefaultmultipurposetraysize</code>
Definition	<p>This operator sets the value for the <code>PageSize</code> of the multipurpose tray slot in the <code>InputAttributes</code> dictionary to the size corresponding to the <i>name</i> parameter. The Boolean value <i>bool</i> is true if the paper feeds short edge first. It is false if the paper feeds long edge first.</p> <p>This operator may be used to notify the interpreter of the default paper size installed in the multipurpose tray. The same function can be performed with the <code>setpagedevice</code> operator.</p> <p>If <code>setdefaultmultipurposetraysize</code> is called at a time when the save level is any other value than zero, an <code>invalidaccess</code> error is returned.</p>
Error(s)	<code>invalidaccess</code> , <code>rangecheck</code> , <code>stackoverflow</code> , <code>typecheck</code>

setdefaultpapertray

Syntax	<i>int</i> setdefaultpapertray -
Definition	<p>This operator copies the values for the <code>PageSize</code>, <code>MediaType</code>, <code>MediaColor</code>, and <code>MediaWeight</code> parameters found in the <code>InputAttributes</code> dictionary for the specified tray, into a dictionary with keys for <code>PageSize</code>, <code>MediaType</code>, <code>MediaColor</code>, and <code>MediaWeight</code>.</p> <p>The requested tray number in the <i>int</i> parameter is also written into the first element of the <code>Priority</code> array in the <code>InputAttributes</code> dictionary, and placed in the dictionary being built. The new dictionary is passed to the <code>setpagedevice</code> operator, and the requested tray is selected as the default paper tray for printing. This paper tray will be used by any PostScript job that doesn't expressly request another paper size.</p> <p>If <code>setdefaultpapertray</code> is called at a time when the save level is any value other than zero, an <code>invalidaccess</code> error is returned.</p>
Error(s)	<code>invalidaccess</code> , <code>rangecheck</code> , <code>stackunderflow</code> , <code>typecheck</code>

setpapertray

Syntax	<i>int</i> setpapertray -
Definition	<p>This operator copies the values for the <code>PageSize</code>, <code>MediaType</code>, <code>MediaColor</code>, and <code>MediaWeight</code> parameters found in the <code>InputAttributes</code> dictionary for the specified tray, into a dictionary with keys for <code>PageSize</code>, <code>MediaType</code>, <code>MediaColor</code>, and <code>MediaWeight</code>.</p> <p>The requested tray number in the <i>int</i> parameter is also written into the first element of the <code>Priority</code> array in the <code>InputAttributes</code> dictionary, and placed in the dictionary being built. The new dictionary is passed to the <code>setpagedevice</code> operator, and the requested paper tray is selected. This paper tray will be used by any PostScript job that doesn't expressly request another paper size.</p>
Error(s)	<code>rangecheck</code> , <code>stackunderflow</code> , <code>typecheck</code>

Index

A

a4 page size operator 78
a4small page size operator 78
a4tray paper tray operator 79
a4tray paper tray selection operator 20
a5 page size operator 78
a5tray paper tray operator 79
a5tray paper tray selection operator 20
AccurateScreens user parameter 37
ActivityReport fax device parameter 58
Adobe Intelligent Software 5
Adobe PostScript programming language 18
AIS 5
antialiasing 2

B

b5 page size operator 78
b5tray paper tray operator 79
b5tray paper tray selection operators 20
BeginPage page device parameter 22
BlockSize %disk0% device parameter 45
BlockSize %rom% device parameter 46
BootDelay %Scsi% bus device parameter 57
BuildTime system parameter 39
Bus %disk0% device parameter 45
ByteOrder system parameter 39

C

c5 page size operator 78
c5tray paper tray operator 79
c5tray paper tray selection operator 20
CalleePhone FaxOptions dictionary parameter 29
CallerID FaxOptions dictionary parameter 29
CallerPhone FaxOptions dictionary parameter 29
CartridgeID %rom% device parameter 46
CartridgeType %rom% device parameter 46
cassettes 14
Category resource for defining new categories 73
Centronics
 connector signal descriptions 8
 interface timing 9
 parallel connector 7

Centronics IEEE 1284 parallel port 3
CheckParity %Scsi% bus device parameter 57
Clock hardware options instance 73
ColorRendering implicit resource category 71
ColorRenderingType implicit resource category 71
ColorSpaceFamily implicit resource category 71
ColorSpace implicit resource category 71
com10 page size operator 78
com10tray paper tray operator 79
com10tray paper tray selection operator 20
communication device parameters 47–56
communication ports 4–9
compatibility operators 77
 descriptions 79–82
 overview 76
 page size 78
 paper tray 79
configuration switch 9–11
Confirmation FaxOptions dictionary parameter 30
connectors
 Centronics parallel 7
 Ethernet 5
 LocalTalk 6
 parallel 7
controller board 11, 12
controller processor 3
Copies FaxOptions dictionary parameter 30
Copies LaserJet III emulator parameter 62
CoverNote FaxOptions dictionary parameter 30
CoverSheet FaxOptions dictionary parameter 30
CoverSheetOnly FaxOptions dictionary parameter 30
CurDisplayList system parameter 39
CurFontCache system parameter 39
CurFormCache system parameter 39
CurInputDevice system parameter 39
CurOutlineCache system parameter 39
CurOutputDevice system parameter 39
CurPatternCache system parameter 39
currentdevparams operator 44
currentpagedevice operator 21
CurScreenStorage system parameter 40
CurSourceList system parameter 40
CurStoredScreenCache system parameter 40
CurUPathCache system parameter 40

D

Darkness %Engine% device parameter 57
 DefaultCaptionOn fax device parameter 58
 DefaultConfirmOn fax device parameter 58
 DefaultCoversOn fax device parameter 59
 DefaultResolution fax device parameter 59
 DefaultRetryCount fax device parameter 59
 DefaultRetryInterval fax device parameter 59
 DelayedOutputClose EtherTalk parameter 52
 DelayedOutputClose LocalTalk parameter 48
 DelayedOutputClose network interface parameter 53
 DelayedOutputClose network printer parameter 55
 DelayedOutputClose parallel port parameter 50
 details dictionary 35
 device parameters 44–66
 device setup 21
 DialCallee FaxOptions dictionary parameter 31
 DialToneWaitPeriod fax device parameter 59
 %disk0% device parameters 44–46
 dl page size operator 78
 dltray paper tray operator 79
 dltray paper tray selection operator 20
 DoStartPage system parameter 40
 DRAM 4, 11
 DRAM expansion 11
 driver 18
 Duplex LaserJet III emulator parameter 62

E

EEPROM 4
 emulation modes 4
 Emulator implicit resource category 71
 emulator parameters 61–66
 Enabled EtherTalk parameter 52
 Enabled LocalTalk parameter 48
 Enabled network interface parameter 54
 Enabled network printer parameter 56
 Enabled parallel port parameter 50
 Encoding regular resource category 68
 EndPage page device parameter 22
 %Engine% device parameters 57
 parameters
 %Engine% device 57
 EPROM 11
 ErrorCorrect FaxOptions dictionary parameter 31
 EthernetAddress EtherTalk parameter 52
 EthernetAddress network interface parameter 54
 Ethernet connector 5
 EthernetType network interface parameter 54
 EtherTalk parameters 52–53

EtherTalk protocols 5
 EtherTalkType EtherTalk parameter 52
 EtherTalkZone EtherTalk parameter 52
 ExitJamRecovery /Fax page device parameter 28
 ExitJamRecovery /FaxReceived page device parameter 27
 ExitJamRecovery page device parameter 22

F

FactoryDefaults system parameter 40
 FatalErrorAddress system parameter 40
 %Fax% device parameters 58–61
 Fax hardware options instance 73
 FaxOptions dictionary 29
 FaxOptions dictionary parameters 29–35
 FaxOptions /Fax page device parameter 28
 FaxOptions page device parameter 22
 Fax output device resource dictionary 70
 /Fax page device parameters 28, 28–29
 fax parameters 29
 FaxReceived output device resource dictionary 70
 /FaxReceived page device parameters 27, 27
 FaxType FaxOptions dictionary parameter 31
 features 3–4
 controller processor 3
 DRAM 4
 EEPROM 4
 emulation modes 4
 fonts 4
 imaging and resolution 3
 interface ports 3
 Page Description Language 4
 paper handling capability 4
 PostScript processing 3
 printing speed 3
 ROM 4
 Filter implicit resource category 71
 Filtering EtherTalk parameter 52
 Filtering LocalTalk parameter 48
 Filtering network interface parameter 54
 Filtering network printer parameter 56
 FinePrint 2
 FMapType implicit resource category 71
 FontFixed LaserJet III emulator parameter 62
 FontHeight LaserJet III emulator parameter 63
 FontItalic LaserJet III emulator parameter 63
 FontNumber LaserJet III emulator parameter 63
 FontPitch LaserJet III emulator parameter 63
 Font regular resource category 68
 FontResourceDir system parameter 40
 fonts 4
 FontSource LaserJet III emulator parameter 64

FontSymbolSet LaserJet III emulator parameter 64
 FontTypeface LaserJet III emulator parameter 64
 FontType implicit resource category 71
 FormWeight LaserJet III emulator parameter 64
 Form regular resource category 69
 FormType implicit resource category 71
 FrameType network interface parameter 54
 Free %disk0% device parameter 45
 Free %rom% device parameter 46

G

GenericResourceDir system parameter 40
 Generic resource for defining new categories 73
 GenericResourcePathSep system parameter 41
 grayscale imaging 2
 Group3Adjustment fax device parameter 59

H

Halftone regular resource category 69
 HalftoneType implicit resource category 71
 Handshake parallel port parameter 50
 HasNames %disk0% device parameter 45
 HasNames %rom% device parameter 46
 HasNames EtherTalk parameter 53
 HasNames LocalTalk parameter 48
 HasNames network interface parameter 54
 HasNames network printer parameter 56
 HasNames parallel port parameter 50
 HostJobID FaxOptions dictionary parameter 30
 HWOptions regular resource category 69
 HWOptions resource category 73
 HWRolution key-value pair 70
 HWRolution /Fax page device parameter 28
 HWRolution /FaxReceived page device parameter 27
 HWRolution key-value pair 70
 HWRolution page device parameter 22

I

ID fax device parameter 59
 ImageType implicit resource category 72
 imaging and resolution 3
 ImagingBBox /Fax page device parameter 28
 ImagingBBox /FaxReceived page device parameter 27
 ImagingBBox page device parameter 22

InitializeAction %disk0% device parameter 45
 InitializeAction %rom% device parameter 46
 InitiatorID %Scsi% bus device parameter 57
 InputAttributes /Fax page device parameter 28
 InputAttributes /FaxReceived page device parameter 27
 InputAttributes page device parameter 23
 Install /Fax page device parameter 28
 Install /FaxReceived page device parameter 27
 Install page device parameter 23
 interpreter parameters 36–66
 interface ports 3
 interface timing, Centronics 9
 Interleave %disk0% device parameter 45
 interpreter 18
 Interpreter EtherTalk parameter 53
 Interpreter LocalTalk parameter 49
 Interpreter network interface parameter 54
 Interpreter network printer parameter 56
 Interpreter parallel port parameter 51
 IODevice implicit resource category 72
 I/O expansion options 3
 IPAddress network interface parameter 54

J

JobName user parameter 37
 JobTimeout system parameter 41
 JobTimeout user parameter 37

K

key-value pairs for Fax output devices 70
 key-value pairs for FaxReceived output devices 70
 key-value pairs for Printer output devices 70

L

Landscape LaserJet III emulator parameter 65
 languagelevel product string value 35
 LaserJet III emulator parameters 61–66
 LaserWriter Utility 19
 legal page size operator 78
 legaltray paper tray operator 79
 legaltray paper tray selection operator 20
 letter page size operator 78
 lettersmall page size operator 78
 lettertray paper tray operator 79
 lettertray paper tray selection operator 20

LicenseID system parameter 41
 Linewrap LaserJet III emulator parameter 65
 LocalLanguage fax device parameter 60
 LocalTalk connector 6
 LocalTalk parameters 48–49
 LocalTalk port 2
 LocalTalk signal descriptions 7
 LocalTalkType LocalTalk parameter 49
 LogicalSize %disk0% device parameter 45
 LogicalSize %rom% device parameter 46

M

MailingTime FaxOptions dictionary parameter 32
 manual feeder 14
 ManualFeed /Fax page device parameter 28
 ManualFeed /FaxReceived page device parameter 27
 ManualFeed page device parameter 23
 ManualFeedTimeout /FaxReceived page device parameter 27
 ManualFeedTimeout page device parameter 24
 ManualSize key-value pair 70
 Margins page device parameter 24
 masked ROM 11
 MaxDictStack user parameter 37
 MaxDisplayList system parameter 41
 MaxExecStack user parameter 37
 MaxFaxBuffer fax device parameter 60
 MaxFontCache system parameter 41
 MaxFontItem user parameter 37
 MaxFormCache system parameter 41
 MaxFormItem user parameter 37
 MaxImageBuffer system parameter 42
 MaxLJMemory LaserJet III emulator parameter 65
 MaxLocalVM user parameter 37
 MaxOpStack user parameter 37
 MaxOutlineCache system parameter 42
 MaxPatternCache system parameter 42
 MaxPatternItem user parameter 37
 MaxRasterMemory system parameter 42
 MaxRetries FaxOptions dictionary parameter 32
 MaxScreenItem user parameter 37
 MaxScreenStorage system parameter 42
 MaxSourceList system parameter 42
 MaxUPathCache system parameter 42
 MaxUPathItem user parameter 38
 MediaColor /Fax page device parameter 28
 MediaColor /FaxReceived page device parameter 27
 MediaColor page device parameter 24
 MediaType /Fax page device parameter 28
 MediaType /FaxReceived page device parameter 27

MediaType page device parameter 24
 MediaWeight /Fax page device parameter 28
 MediaWeight /FaxReceived page device parameter 27
 MediaWeight page device parameter 24
 memory capabilities 11
 MinFontCompress user parameter 38
 monarch page size operator 78
 monarchtray paper tray operator 79
 monarchtray paper tray selection operator 20
 Mounted %disk0% device parameter 45
 Mounted %rom% device parameter 46
 MROM 11

N

NetWare protocols 5
 network interface parameters 53–55
 NetworkName network interface parameter 54
 network printer parameters 55–56
 NodeID LocalTalk parameter 49
 note page size operator 78
 nPages FaxOptions dictionary parameter 32
 NumCopies /Fax page device parameter 29
 NumCopies /FaxReceived page device parameter 27
 NumCopies page device parameter 24

O

On EtherTalk parameter 53
 On LocalTalk parameter 49
 On network interface parameter 55
 On network printer parameter 56
 On parallel port parameter 51
 operators
 compatibility 77
 paper tray selection 20
 OutputDevice /Fax page device parameter 29
 OutputDevice /FaxReceived page device parameter 27
 OutputDevice page device parameter 24
 OutputDevice parallel port parameter 51
 OutputDevice regular resource category 69
 OutputFaceUp /FaxReceived page device parameter 27
 OutputFaceUp page device parameter 24
 OutputPage /Fax page device parameter 29
 OutputPage /FaxReceived page device parameter 27
 OutputPage page device parameter 25

P, Q

PageCaption FaxOptions dictionary parameter 32
 PageCount %Engine% device parameter 58
 PageCount system parameter 43
 Page Description Language 4
 page device parameters 21–26
 page size 13
 page size compatibility operators 78
 PageSize /Fax page device parameter 29
 PageSize /FaxReceived page device parameter 27
 PageSize key-value pair 70
 PageSize page device parameter 25
 PageSizePolicy key 78
 page types 13, 19
 paper cassettes 14
 paper handling capability 4
 paper handling options 14
 PaperSize LaserJet III emulator parameter 65
 paper sizes 13, 26
 paper tray compatibility operators 79
 paper tray selection operators 20
 paper tray slot numbers and input sources 27
 parallel port parameters 50–51
 parameters
 communication device 47–56
 device 44–66
 EtherTalk 52–53
 fax 29–35
 fax devices 58–61
 file system %disk0% devices 44–46
 file system %rom% devices 46–47
 interpreter 36–66
 LaserJet III emulator 61–66
 LocalTalk 48–49
 network interface 53–55
 network printer 55–56
 page device 21–26
 parallel port 50–51
 SCSI bus devices 56
 system 38–44
 user 36–38
 Pattern regular resource category 69
 PatternType implicit resource category 72
 PDL 4
 PhotoGrade 2
 PhysicalSize %disk0% device parameter 45
 PhysicalSize %rom% device parameter 47
 Policies page device parameter 25
 Poll %Scsi% bus device parameter 57
 ports 4–9
 Centronics parallel 2
 Ethernet 2, 5
 LocalTalk 2, 6

PostRenderingEnhanceDetails page device
 parameter 25
 PostRenderingEnhance page device parameter 25
 PostScript interpreter 18
 PostScript Level 2 implementation 21
 PostScriptPassword fax device parameter 60
 PostScriptPassword FaxOptions dictionary
 parameter 32
 PostScript processing 3
 PostScript programming language 18
 PreRenderingEnhanceDetails page device
 parameter 26
 PreRenderingEnhance page device parameter 26
 printable area 13
 printer driver 18
 printer features 3–4
 PrinterMode system parameter 43
 PrinterName system parameter 43
 Printer output device resource dictionary 70
 printing speed 3
 ProcessColorModel key-value pair 70
 ProcessColorModelIn key-value pair 70
 ProcInfo FaxOptions dictionary parameter 33
 ProcSet regular resource category 69
 product product string value 35
 product strings 35
 programming language 18
 Protocol parallel port parameter 51
 ProtocolVersion fax device parameter 60

R

RAMSize system parameter 43
 RealFormat system parameter 43
 rear-panel connectors 5
 ReceivePostScript fax device parameter 60
 RecipientID FaxOptions dictionary parameter 33
 RecipientLanguage FaxOptions dictionary
 parameter 33
 RecipientMailStop FaxOptions dictionary
 parameter 33
 RecipientName FaxOptions dictionary
 parameter 33
 RecipientOrg FaxOptions dictionary parameter 33
 RecipientPhone FaxOptions dictionary
 parameter 33
 Regarding FaxOptions dictionary parameter 34
 regular resource categories 68–69
 Removable %disk0% device parameter 45
 Removable %rom% device parameter 47
 resource categories 67–73
 implicit instances 71

resources
 defining new categories 73
 RetryInterval FaxOptions dictionary
 parameter 34
 RevertToRaster FaxOptions dictionary
 parameter 34
 revision product string value 35
 Revision system parameter 43
 Rings fax device parameter 61
 ROM 4
 %rom% device parameters 46–47
 ROM capability 11
 ROMVersion network interface parameter 55

S

%Scsi% bus device parameters 56
 Searchable %disk0% device parameter 45
 Searchable %rom% device parameter 47
 SearchOrder %disk0% device parameter 46
 SearchOrder %rom% device parameter 47
 SenderID FaxOptions dictionary parameter 34
 SenderMailStop FaxOptions dictionary
 parameter 34
 SenderName FaxOptions dictionary parameter 34
 SenderOrg FaxOptions dictionary parameter 34
 SenderPhone FaxOptions dictionary parameter 34
 serialnumber product string value 35
 ServiceEnable fax device parameter 61
 setdevparams operator 44
 signal descriptions
 Centronics connector 8
 LocalTalk 7
 SIMM card 11, 12
 software overview 18–20
 Speaker fax device parameter 61
 StartJobPassword system parameter 43
 StartupMode system parameter 43
 statusdict dictionary 76
 status lights 15
 StorageDevice fax device parameter 61
 Symbol Set code, legal values 66–67
 system parameters 38–44
 SystemParamsPassword system parameter 43

T

TargetID %Scsi% bus device parameter 57
 TCP/IP protocols 6
 TimeToStandby %Engine% device parameter 58
 timing, Centronics 9

TopMargins LaserJet III emulator parameter 65
 TraySwitch page device parameter 26
 TrimWhite FaxOptions dictionary parameter 35
 Type %disk0% device parameter 46
 Type %Engine% device parameter 58
 Type %rom% device parameter 47
 Type %Scsi% bus device parameter 57
 Type EtherTalk parameter 53
 Type fax device parameter 61
 Type LaserJet III emulator parameter 66
 Type LocalTalk parameter 49
 Type network interface parameter 55
 Type network printer parameter 56
 Type parallel port parameter 51

U

upgrading printer memory 11
 userdict dictionary 76
 user parameters 36–38
 utility program 19

V

ValidNV system parameter 44
 version product string value 35
 VMI LaserJet III emulator parameter 66
 VMReclaim user parameter 38
 VMThreshold user parameter 38

W, X, Y, Z

WaitForDialTone fax device parameter 61
 WaitTimeout LaserJet III emulator parameter 66
 WaitTimeout system parameter 44
 WaitTimeout user parameter 38
 Writeable %disk0% device parameter 46
 Writeable %rom% device parameter 47

This Apple manual was written, edited, and composed on a desktop publishing system using Apple Macintosh computers and FrameMaker software. Proof pages and final pages were created on an Apple LaserWriter Pro printer. Line art was created using Adobe Illustrator™ and Adobe Photoshop™. PostScript™, the page-description language for the LaserWriter, was developed by Adobe Systems Incorporated.

Text type is Palatino® and display type is Helvetica®. Bullets are ITC Zapf Dingbats®. Some elements, such as program listings, are set in Apple Courier.

WRITER

Steve Schwander

DEVELOPMENTAL EDITOR

Wendy Krafft

ILLUSTRATORS

Deb Dennis and Shawn Morningstar

PRODUCTION EDITOR

Rex Wolf

Special thanks to Mike Cook,
Timothy Mac, Bill Ohtola, and
Claude Wright